

LM2598 SIMPLE SWITCHER[®] Power Converter 150 kHz 1A Step-Down Voltage Regulator, with Features

Check for Samples: [LM2598](#)

FEATURES

- 3.3V, 5V, 12V, and Adjustable Output Versions
- Adjustable Version Output Voltage Range, 1.2V to 37V \pm 4% Max Over Line and Load Conditions
- Ensured 1A Output Current
- Available in 7-Pin TO-220 and DDPAK (Surface Mount) Package
- Input Voltage Range Up to 40V
- Excellent Line and Load Regulation Specifications
- 150 kHz Fixed Frequency Internal Oscillator
- Shutdown /Soft-start
- Out of Regulation Error Flag
- Error Output Delay
- Low Power Standby Mode, I_Q Typically 85 μ A
- High Efficiency
- Uses Readily Available Standard Inductors
- Thermal Shutdown and Current Limit Protection

APPLICATIONS

- Simple High-Efficiency Step-down (Buck) Regulator
- Efficient Pre-Regulator for Linear Regulators
- On-Card Switching Regulators
- Positive to Negative Converter

DESCRIPTION

The LM2598 series of regulators are monolithic integrated circuits that provide all the active functions for a step-down (buck) switching regulator, capable of driving a 1A load with excellent line and load regulation. These devices are available in fixed output voltages of 3.3V, 5V, 12V, and an adjustable output version.

This series of switching regulators is similar to the LM2595 series, with additional supervisory and performance features added.

Requiring a minimum number of external components, these regulators are simple to use and include internal frequency compensation†, improved line and load specifications, fixed-frequency oscillator, Shutdown /Soft-start, error flag delay and error flag output.

The LM2598 series operates at a switching frequency of 150 kHz thus allowing smaller sized filter components than what would be needed with lower frequency switching regulators. Available in a standard 7-lead TO-220 package with several different lead bend options, and a 7-lead DDPAK surface mount package. Typically, for output voltages less than 12V, and ambient temperatures less than 50°C, no heat sink is required.

A standard series of inductors (both through hole and surface mount types) are available from several different manufacturers optimized for use with the LM2598 series. This feature greatly simplifies the design of switch-mode power supplies.

Other features include a specified \pm 4% tolerance on output voltage under all conditions of input voltage and output load conditions, and \pm 15% on the oscillator frequency. External shutdown is included, featuring typically 85 μ A standby current. Self protection features include a two stage current limit for the output switch and an over temperature shutdown for complete protection under fault conditions. ⁽¹⁾

(1) † Patent Number 5,382,918



Please be aware that an important notice concerning availability, standard warranty, and use in critical applications of Texas Instruments semiconductor products and disclaimers thereto appears at the end of this data sheet.

SIMPLE SWITCHER is a registered trademark of Texas Instruments.

All other trademarks are the property of their respective owners.

Typical Application

(Fixed Output Voltage Versions)

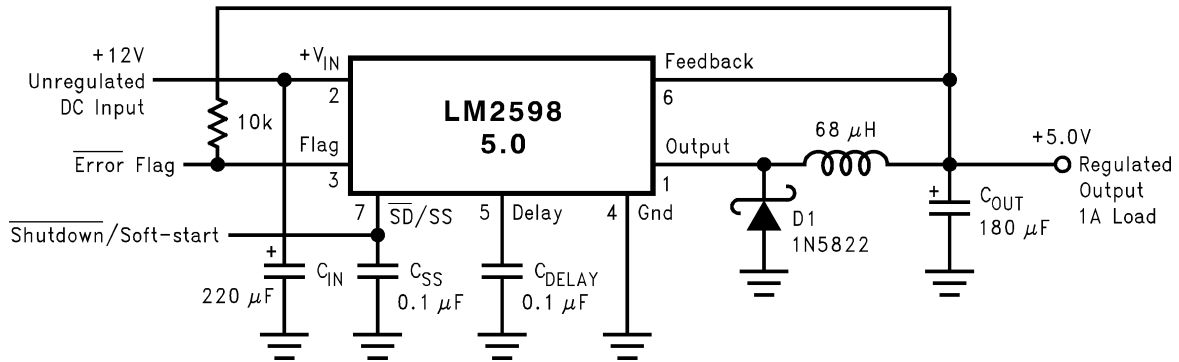

Connection Diagrams

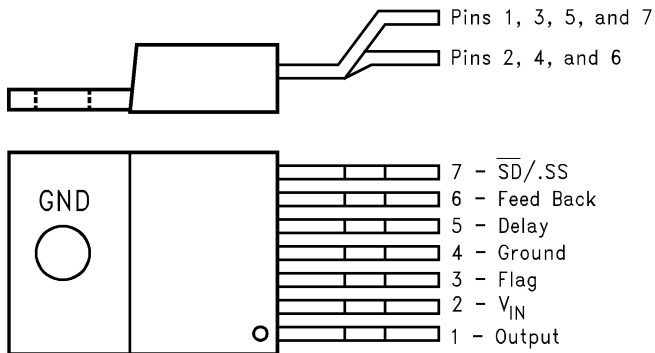

Figure 1. 7-Lead Bent and Staggered Leads, Through Hole TO-220 (T) Package
See Package Number NDZ0007B

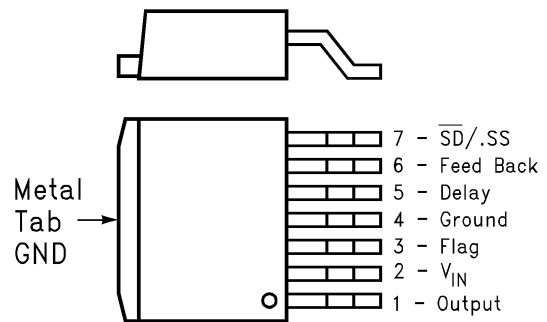

Figure 2. 7-Lead Surface Mount DPAK (S) Package
See Package Number KTW0007B



These devices have limited built-in ESD protection. The leads should be shorted together or the device placed in conductive foam during storage or handling to prevent electrostatic damage to the MOS gates.

Absolute Maximum Ratings ⁽¹⁾⁽²⁾

| | |
|--|-------------------------|
| Maximum Supply Voltage (V_{IN}) | 45V |
| \overline{SD} /SS Pin Input Voltage ⁽³⁾ | 6V |
| Delay Pin Voltage ⁽³⁾ | 1.5V |
| Flag Pin Voltage | $-0.3 \leq V \leq +45V$ |
| Feedback Pin Voltage | $-0.3 \leq V \leq +25V$ |
| Output Voltage to Ground | |
| (Steady State) | -1V |
| Power Dissipation | Internally limited |
| Storage Temperature Range | -65°C to +150°C |
| ESD Susceptibility | |
| Human Body Model ⁽⁴⁾ | 2 kV |
| Lead Temperature | |
| S Package | |
| Vapor Phase (60 sec.) | +215°C |
| Infrared (10 sec.) | +245°C |
| T Package (Soldering, 10 sec.) | +260°C |
| Maximum Junction Temperature | +150°C |

- (1) Absolute Maximum Ratings indicate limits beyond which damage to the device may occur. Operating Ratings indicate conditions for which the device is intended to be functional, but do not ensure specific performance limits. For ensured specifications and test conditions, see the Electrical Characteristics.
- (2) If Military/Aerospace specified devices are required, please contact the Texas Instruments Sales Office/ Distributors for availability and specifications.
- (3) Voltage internally clamped. If clamp voltage is exceeded, limit current to a maximum of 1 mA.
- (4) The human body model is a 100 pF capacitor discharged through a 1.5k resistor into each pin.

Operating Conditions

| | |
|-------------------|--|
| Temperature Range | $-25^{\circ}\text{C} \leq T_J \leq +125^{\circ}\text{C}$ |
| Supply Voltage | 4.5V to 40V |

LM2598-3.3 Electrical Characteristics

Specifications with standard type face are for $T_J = 25^{\circ}\text{C}$, and those with **boldface type** apply over **full Operating Temperature Range**.

| Symbol | Parameter | Conditions | LM2598-3.3 | | Units (Limits) |
|--|----------------|--|--------------------|--|-----------------------|
| | | | Typ ⁽¹⁾ | Limit ⁽²⁾ | |
| SYSTEM PARAMETERS ⁽³⁾ Test Circuit Figure 24 | | | | | |
| V_{OUT} | Output Voltage | $4.75V \leq V_{IN} \leq 40V, 0.1A \leq I_{LOAD} \leq 1A$ | 3.3 | 3.168/ 3.135 3.432/ 3.465 | V V(min) V(max) |
| η | Efficiency | $V_{IN} = 12V, I_{LOAD} = 1A$ | 78 | | % |

- (1) Typical numbers are at 25°C and represent the most likely norm.
- (2) All limits specified at room temperature (standard type face) and at **temperature extremes (bold type face)**. All room temperature limits are 100% production tested. All limits at **temperature extremes** are specified via correlation using standard Statistical Quality Control (SQC) methods. All limits are used to calculate Average Outgoing Quality Level (AOQL).
- (3) External components such as the catch diode, inductor, input and output capacitors can affect switching regulator system performance. When the LM2598 is used as shown in the [Figure 24](#) test circuit, system performance will be as shown in system parameters of Electrical Characteristics section.

LM2598-5.0 Electrical Characteristics

Specifications with standard type face are for $T_J = 25^\circ\text{C}$, and those with **boldface type** apply over **full Operating Temperature Range**.

| Symbol | Parameter | Conditions | LM2598-5.0 | | Units (Limits) |
|--|----------------|---|--------------------|--|-----------------------|
| | | | Typ ⁽¹⁾ | Limit ⁽²⁾ | |
| SYSTEM PARAMETERS ⁽³⁾ Test Circuit Figure 24 | | | | | |
| V_{OUT} | Output Voltage | $7V \leq V_{IN} \leq 40V, 0.1A \leq I_{LOAD} \leq 1A$ | 5 | 4.800/ 4.750 5.200/ 5.250 | V V(min) V(max) |
| η | Efficiency | $V_{IN} = 12V, I_{LOAD} = 1A$ | 82 | | % |

- (1) Typical numbers are at 25°C and represent the most likely norm.
- (2) All limits specified at room temperature (standard type face) and at **temperature extremes (bold type face)**. All room temperature limits are 100% production tested. All limits at **temperature extremes** are specified via correlation using standard Statistical Quality Control (SQC) methods. All limits are used to calculate Average Outgoing Quality Level (AOQL).
- (3) External components such as the catch diode, inductor, input and output capacitors can affect switching regulator system performance. When the LM2598 is used as shown in the [Figure 24](#) test circuit, system performance will be as shown in system parameters of Electrical Characteristics section.

LM2598-12 Electrical Characteristics

Specifications with standard type face are for $T_J = 25^\circ\text{C}$, and those with **boldface type** apply over **full Operating Temperature Range**.

| Symbol | Parameter | Conditions | LM2598-12 | | Units (Limits) |
|--|----------------|--|--------------------|--|-----------------------|
| | | | Typ ⁽¹⁾ | Limit ⁽²⁾ | |
| SYSTEM PARAMETERS ⁽³⁾ Test Circuit Figure 24 | | | | | |
| V_{OUT} | Output Voltage | $15V \leq V_{IN} \leq 40V, 0.1A \leq I_{LOAD} \leq 1A$ | 12 | 11.52/ 11.40 12.48/ 12.60 | V V(min) V(max) |
| η | Efficiency | $V_{IN} = 25V, I_{LOAD} = 1A$ | 90 | | % |

- (1) Typical numbers are at 25°C and represent the most likely norm.
- (2) All limits specified at room temperature (standard type face) and at **temperature extremes (bold type face)**. All room temperature limits are 100% production tested. All limits at **temperature extremes** are specified via correlation using standard Statistical Quality Control (SQC) methods. All limits are used to calculate Average Outgoing Quality Level (AOQL).
- (3) External components such as the catch diode, inductor, input and output capacitors can affect switching regulator system performance. When the LM2598 is used as shown in the [Figure 24](#) test circuit, system performance will be as shown in system parameters of Electrical Characteristics section.

LM2598-ADJ Electrical Characteristics

Specifications with standard type face are for $T_J = 25^\circ\text{C}$, and those with **boldface type** apply over **full Operating Temperature Range**.

| Symbol | Parameter | Conditions | LM2598-ADJ | | Units (Limits) |
|--|------------------|---|--------------------|--|-----------------------|
| | | | Typ ⁽¹⁾ | Limit ⁽²⁾ | |
| SYSTEM PARAMETERS ⁽³⁾ Test Circuit Figure 24 | | | | | |
| V_{FB} | Feedback Voltage | $4.5\text{V} \leq V_{IN} \leq 40\text{V}$, $0.1\text{A} \leq I_{LOAD} \leq 1\text{A}$ V_{OUT} programmed for 3V. Circuit of Figure 29 . | 1.230 | 1.193/ 1.180 1.267/ 1.280 | V V(min) V(max) |
| η | Efficiency | $V_{IN} = 12\text{V}$, $V_{OUT} = 3\text{V}$, $I_{LOAD} = 1\text{A}$ | 78 | | % |

- (1) Typical numbers are at 25°C and represent the most likely norm.
- (2) All limits specified at room temperature (standard type face) and at **temperature extremes (bold type face)**. All room temperature limits are 100% production tested. All limits at **temperature extremes** are specified via correlation using standard Statistical Quality Control (SQC) methods. All limits are used to calculate Average Outgoing Quality Level (AOQL).
- (3) External components such as the catch diode, inductor, input and output capacitors can affect switching regulator system performance. When the LM2598 is used as shown in the [Figure 24](#) test circuit, system performance will be as shown in system parameters of Electrical Characteristics section.

All Output Voltage Versions Electrical Characteristics

Specifications with standard type face are for $T_J = 25^\circ\text{C}$, and those with **boldface type** apply over **full Operating Temperature Range**. Unless otherwise specified, $V_{IN} = 12\text{V}$ for the 3.3V, 5V, and Adjustable version and $V_{IN} = 24\text{V}$ for the 12V version. $I_{LOAD} = 200\text{mA}$

| Symbol | Parameter | Conditions | LM2598-XX | | Units (Limits) |
|--------------------------|-----------------------------|--|--------------------|-------------------------------------|-----------------------------|
| | | | Typ ⁽¹⁾ | Limit ⁽²⁾ | |
| DEVICE PARAMETERS | | | | | |
| I_b | Feedback Bias Current | Adjustable Version Only, $V_{FB} = 1.3\text{V}$ | 10 | 50/ 100 | nA nA(max) |
| f_o | Oscillator Frequency | See ⁽³⁾ | 150 | 127/ 110 173/ 173 | kHz kHz(min) kHz(max) |
| V_{SAT} | Saturation Voltage | $I_{OUT} = 1\text{A}$ ⁽⁴⁾ ⁽⁵⁾ | 1 | 1.2/ 1.3 | V V(max) |
| DC | Max Duty Cycle (ON) | See ⁽⁵⁾ | 100 | | % |
| | Min Duty Cycle (OFF) | See ⁽⁶⁾ | 0 | | |
| I_{CL} | Current Limit | Peak Current, ⁽⁴⁾ ⁽⁵⁾ | 1.5 | 1.2/ 1.15 2.4/ 2.6 | A A(min) A(max) |
| I_L | Output Leakage Current | Output = 0V ⁽⁵⁾ ⁽⁶⁾ ⁽⁷⁾ | | 50 | μA (max) |
| | | Output = -1V | 2 | 15 | mA mA(max) |
| I_Q | Operating Quiescent Current | \overline{SD} /SS Pin Open, ⁽⁶⁾ | 5 | 10 | mA mA(max) |

- (1) Typical numbers are at 25°C and represent the most likely norm.
- (2) All limits specified at room temperature (standard type face) and at **temperature extremes (bold type face)**. All room temperature limits are 100% production tested. All limits at **temperature extremes** are specified via correlation using standard Statistical Quality Control (SQC) methods. All limits are used to calculate Average Outgoing Quality Level (AOQL).
- (3) The switching frequency is reduced when the second stage current limit is activated. The amount of reduction is determined by the severity of current overload.
- (4) No diode, inductor or capacitor connected to output pin.
- (5) Feedback pin removed from output and connected to 0V to force the output transistor switch ON.
- (6) Feedback pin removed from output and connected to 12V for the 3.3V, 5V, and the ADJ. version, and 15V for the 12V version, to force the output transistor switch OFF.
- (7) $V_{IN} = 40\text{V}$.

All Output Voltage Versions Electrical Characteristics (continued)

Specifications with standard type face are for $T_J = 25^\circ\text{C}$, and those with **boldface type** apply over **full Operating Temperature Range**. Unless otherwise specified, $V_{IN} = 12\text{V}$ for the 3.3V, 5V, and Adjustable version and $V_{IN} = 24\text{V}$ for the 12V version. $I_{LOAD} = 200\text{ mA}$

| Symbol | Parameter | Conditions | LM2598-XX | | Units (Limits) |
|--|--|---|-----------|------------------------|--|
| | | | Typ (1) | Limit (2) | |
| I_{STBY} | Standby Quiescent Current | \overline{SD}/SS pin = 0V, (7) | 85 | 200/ 250 | μA $\mu\text{A}(\text{max})$ |
| θ_{JC} | Thermal Resistance | TO220 or DDPACK Package, Junction to Case | 2 | | $^\circ\text{C}/\text{W}$ |
| θ_{JA} | | TO220 Package, Junction to Ambient (8) | 50 | | $^\circ\text{C}/\text{W}$ |
| θ_{JA} | | DDPAK Package, Junction to Ambient (9) | 50 | | $^\circ\text{C}/\text{W}$ |
| θ_{JA} | | DDPAK Package, Junction to Ambient (10) | 30 | | $^\circ\text{C}/\text{W}$ |
| θ_{JA} | | DDPAK Package, Junction to Ambient (11) | 20 | | $^\circ\text{C}/\text{W}$ |
| SHUTDOWN/SOFT-START CONTROL Test Circuit of Figure 24 | | | | | |
| V_{SD} | Shutdown Threshold Voltage | Low, (Shutdown Mode) High, (Soft-start Mode) | 1.3 | 0.6 2 | V V(max) V(min) |
| V_{SS} | Soft-start Voltage | $V_{OUT} = 20\%$ of Nominal Output Voltage $V_{OUT} = 100\%$ of Nominal Output Voltage | 2 3 | | V |
| I_{SD} | Shutdown Current | $\overline{V}_{SHUTDOWN} = 0.5\text{V}$ | 5 | 10 | μA $\mu\text{A}(\text{max})$ |
| I_{SS} | Soft-start Current | $V_{\text{Soft-start}} = 2.5\text{V}$ | 1.6 | 5 | μA $\mu\text{A}(\text{max})$ |
| FLAG/DELAY CONTROL Test Circuit of Figure 24 | | | | | |
| | Regulator Dropout Detector Threshold Voltage | Low (Flag ON) | 96 | 92 98 | % %(min) %(max) |
| V_{FSAT} | Flag Output Saturation Voltage | $I_{SINK} = 3\text{ mA}$ $V_{DELAY} = 0.5\text{V}$ | 0.3 | 0.7/1.0 | V V(max) |
| I_{FL} | Flag Output Leakage Current | $V_{FLAG} = 40\text{V}$ | 0.3 | | μA |
| | Delay Pin Threshold Voltage | Low (Flag ON) High (Flag OFF) and V_{OUT} Regulated | 1.25 | 1.21 1.29 | V V(min) V(max) |
| | Delay Pin Source Current | $V_{DELAY} = 0.5\text{V}$ | 3 | 6 | μA $\mu\text{A}(\text{max})$ |
| | Delay Pin Saturation | Low (Flag ON) | 55 | 350/400 | mV mV(max) |

- (8) Junction to ambient thermal resistance (no external heat sink) for the TO-220 package mounted vertically, with the leads soldered to a printed circuit board with (1 oz.) copper area of approximately 1 in^2 .
- (9) Junction to ambient thermal resistance with the DDPACK package tab soldered to a single sided printed circuit board with 0.5 in^2 of (1 oz.) copper area.
- (10) Junction to ambient thermal resistance with the DDPACK package tab soldered to a single sided printed circuit board with 2.5 in^2 of (1 oz.) copper area.
- (11) Junction to ambient thermal resistance with the DDPACK package tab soldered to a double sided printed circuit board with 3 in^2 of (1 oz.) copper area on the LM2598S side of the board, and approximately 16 in^2 of copper on the other side of the p-c board. See [Application Information](#) in this data sheet and the thermal model in Switchers Made Simple™ version 4.2 software.

Typical Performance Characteristics

(Circuit of [Figure 24](#))

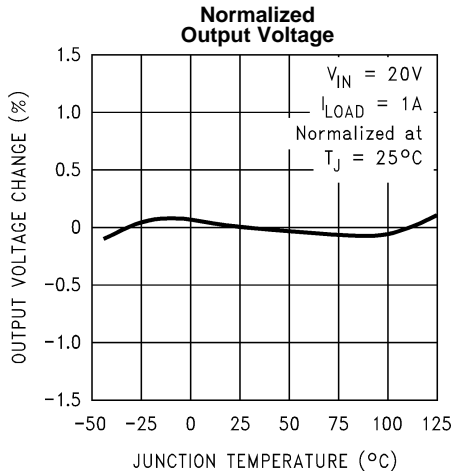

Figure 3.

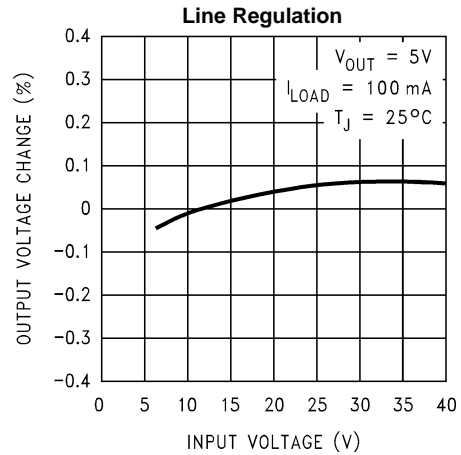

Figure 4.

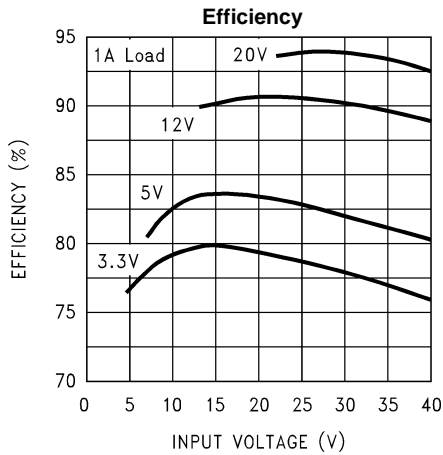

Figure 5.

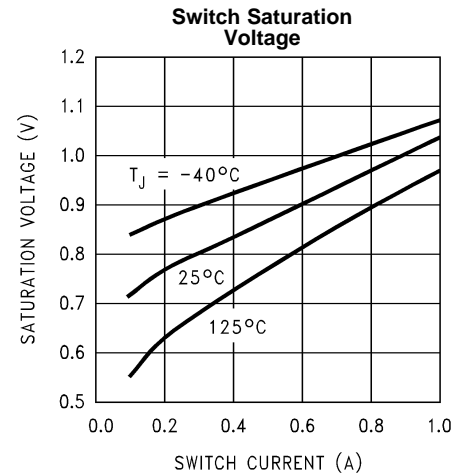

Figure 6.

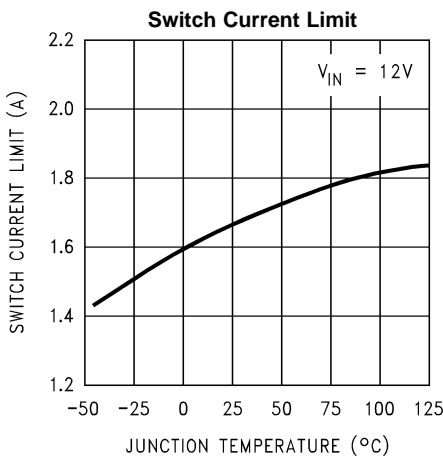

Figure 7.

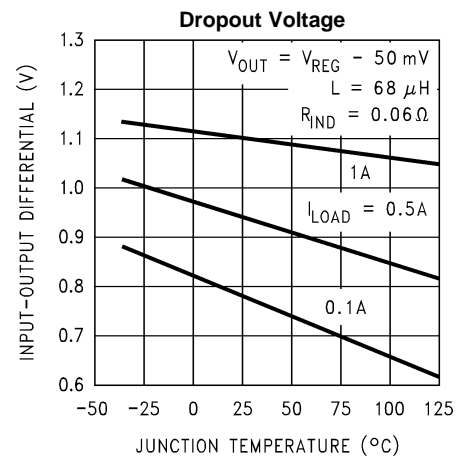

Figure 8.

Typical Performance Characteristics (continued)

(Circuit of [Figure 24](#))

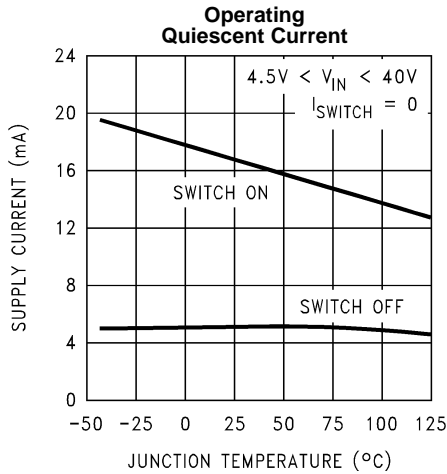

Figure 9.

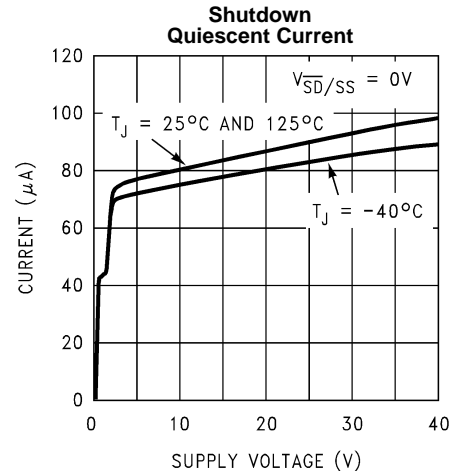

Figure 10.

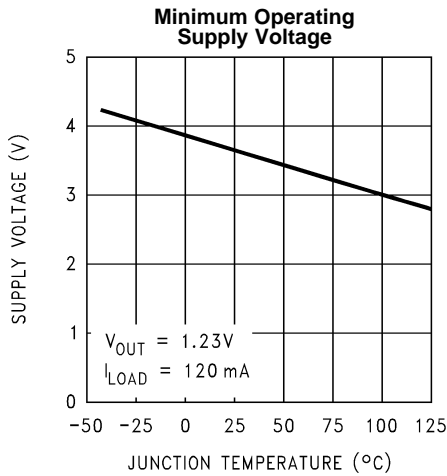

Figure 11.

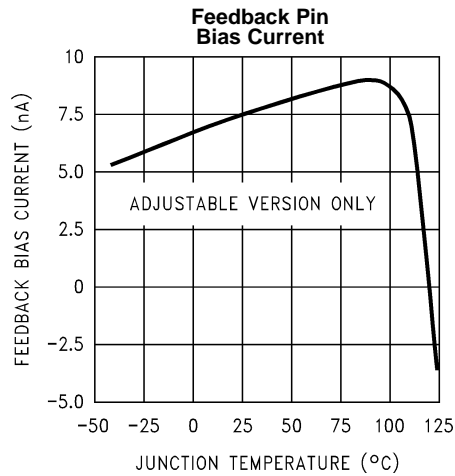

Figure 12.

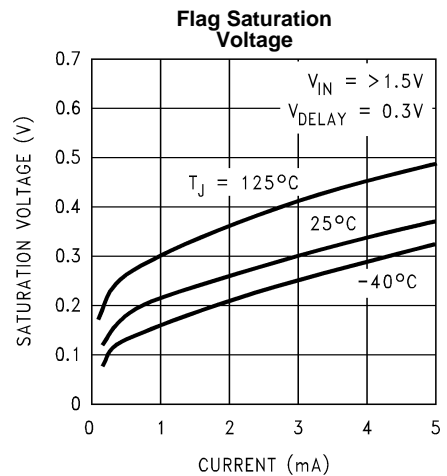

Figure 13.

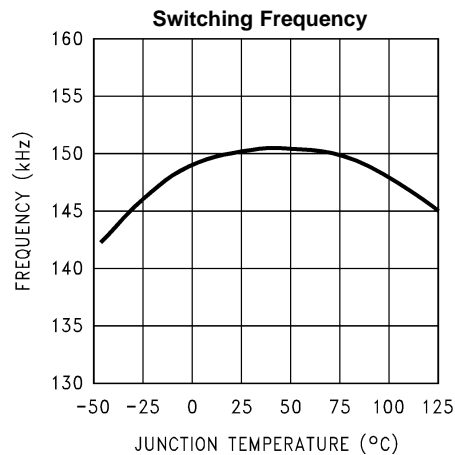

Figure 14.

Typical Performance Characteristics (continued)

(Circuit of Figure 24)

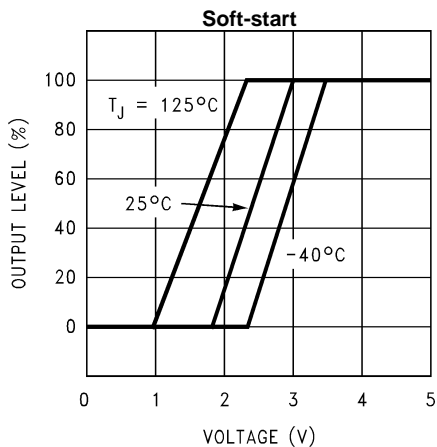

Figure 15.

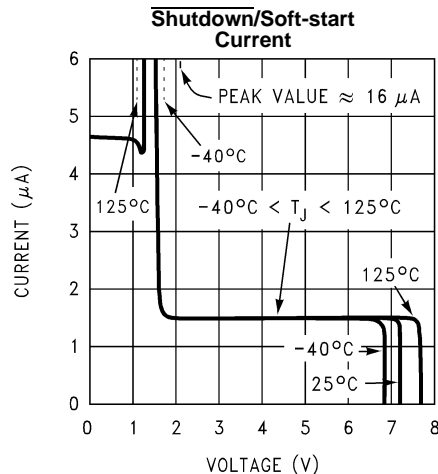

Figure 16.

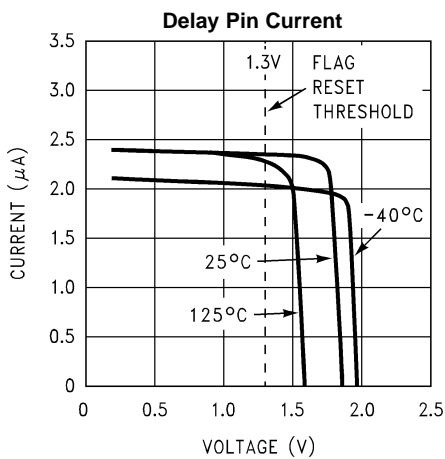

Figure 17.

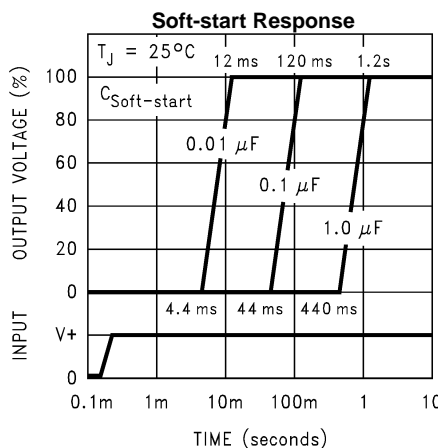

Figure 18.

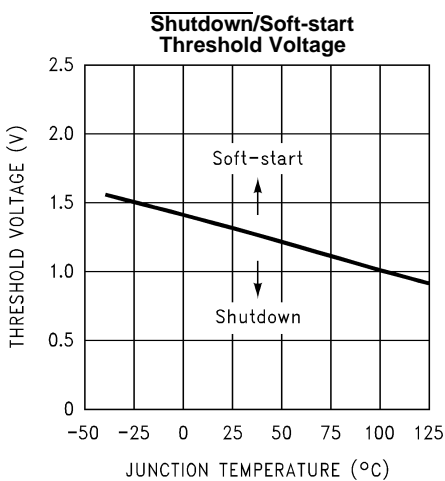
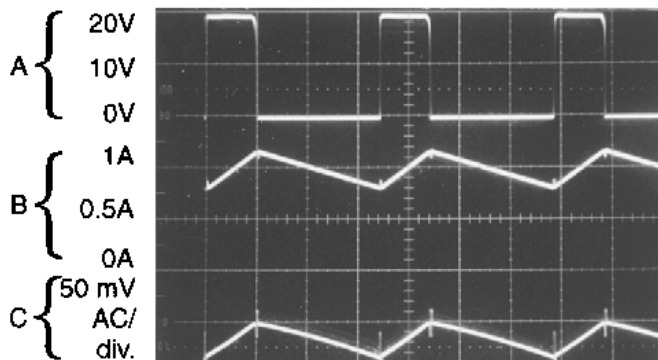

Figure 19.

Continuous Mode Switching Waveforms
 $V_{\text{IN}} = 20\text{V}$, $V_{\text{OUT}} = 5\text{V}$, $I_{\text{LOAD}} = 1\text{A}$
 $L = 68 \mu\text{H}$, $C_{\text{OUT}} = 120 \mu\text{F}$, $C_{\text{OUT ESR}} = 100 \text{m}\Omega$



A: Output Pin Voltage, 10V/div.
 B: Inductor Current 0.5A/div.
 C: Output Ripple Voltage, 50 mV/div.
 Figure 20. Horizontal Time Base: 2 $\mu\text{s}/\text{div}$.

Typical Performance Characteristics (continued)

(Circuit of [Figure 24](#))

Discontinuous Mode Switching Waveforms
 $V_{IN} = 20V, V_{OUT} = 5V, I_{LOAD} = 600\text{ mA}$
 $L = 22\ \mu\text{H}, C_{OUT} = 220\ \mu\text{F}, C_{OUT\ ESR} = 50\ \text{m}\Omega$

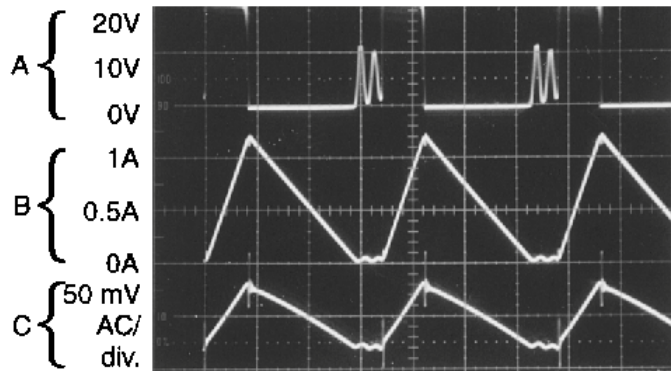

A: Output Pin Voltage, 10V/div.
 B: Inductor Current 0.5A/div.
 C: Output Ripple Voltage, 50 mV/div.

Figure 21. Horizontal Time Base: 2 μs /div.

Load Transient Response for Continuous Mode
 $V_{IN} = 20V, V_{OUT} = 5V, I_{LOAD} = 250\text{ mA to }750\text{ mA}$
 $L = 68\ \mu\text{H}, C_{OUT} = 120\ \mu\text{F}, C_{OUT\ ESR} = 100\ \text{m}\Omega$

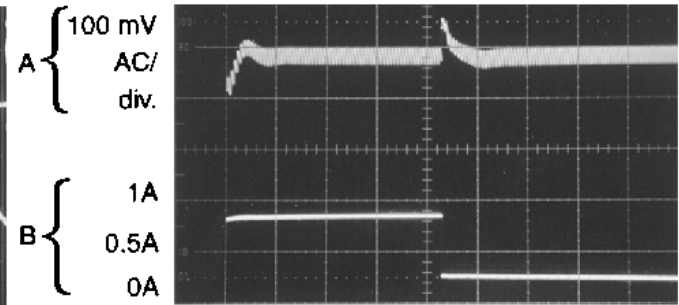

A: Output Voltage, 100 mV/div. (AC)
 B: 250 mA to 750 mA Load Pulse

Figure 22. Horizontal Time Base: 100 μs /div.

Load Transient Response for Discontinuous Mode
 $V_{IN} = 20V, V_{OUT} = 5V, I_{LOAD} = 250\text{ mA to }750\text{ mA}$
 $L = 22\ \mu\text{H}, C_{OUT} = 220\ \mu\text{F}, C_{OUT\ ESR} = 50\ \text{m}\Omega$

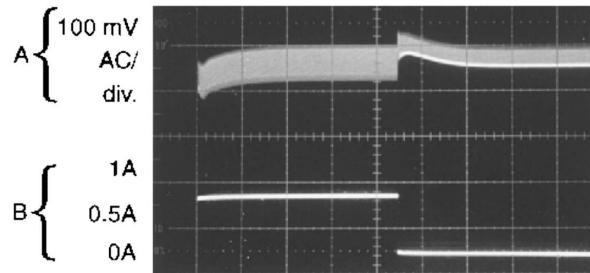

A: Output Voltage, 100 mV/div. (AC)
 B: 250 mA to 750 mA Load Pulse

Figure 23. Horizontal Time Base: 200 μs /div.

Test Circuit and Layout Guidelines

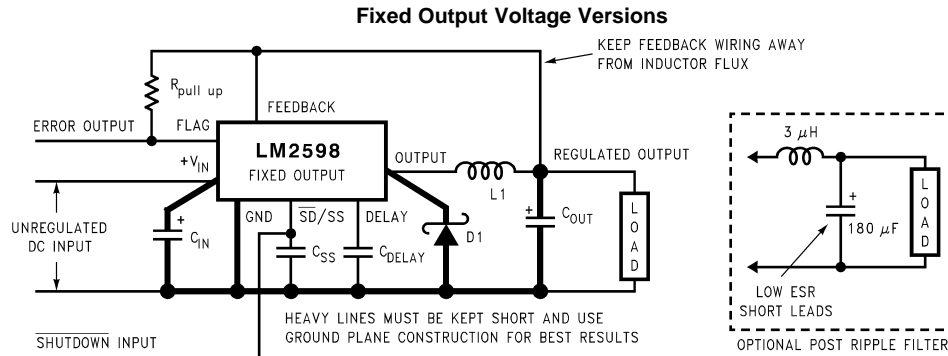

Component Values shown are for $V_{IN} = 15V$, $V_{OUT} = 5V$, $I_{LOAD} = 1A$.

120 μF , 50V, Aluminum Electrolytic Nichicon "PL Series"

120 μF , 35V Aluminum Electrolytic, Nichicon "PL Series"

3A, 40V Schottky Rectifier, 1N5822

68 μH , L30

Typical Values

* C_{SS} : — 0.1 μF

C_{DELAY} : — 0.1 μF

$R_{PULL UP}$: — 4.7k

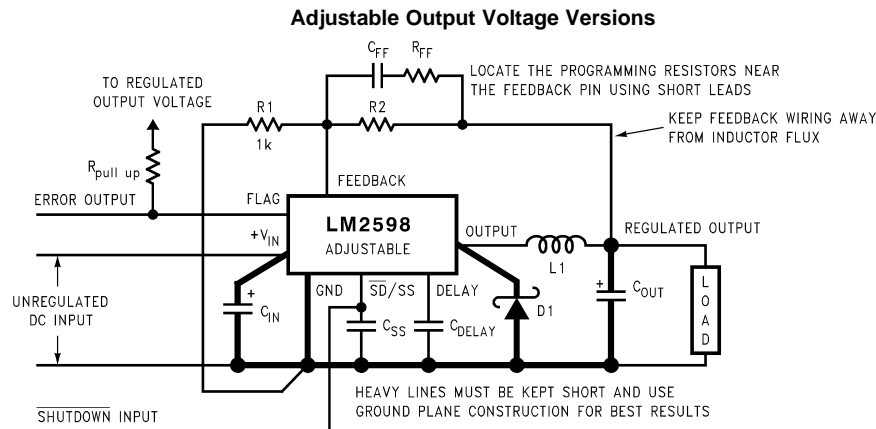

$$V_{OUT} = V_{REF} \left(1 + \frac{R_2}{R_1} \right)$$

where $V_{REF} = 1.23V$

$$R_2 = R_1 \left(\frac{V_{OUT}}{V_{REF}} - 1 \right)$$

Select R_1 to be approximately 1k Ω , use a 1% resistor for best stability.

Component Values shown are for $V_{IN} = 20V$,

$V_{OUT} = 10V$, $I_{LOAD} = 1A$.

C_{IN} — 120 μF , 35V, Aluminum Electrolytic Nichicon "PL Series"

C_{OUT} — 120 μF , 35V Aluminum Electrolytic, Nichicon "PL Series"

D1 — 3A, 40V Schottky Rectifier, 1N5822

L1 — 100 μH , L29

R_1 — 1 k Ω , 1%

R_2 — 7.15k, 1%

C_{FF} — 3.3 nF, See [Application Information](#) Section

R_{FF} — 3 k Ω , See [Application Information](#) Section

Typical Values

C_{SS} —0.1 μF

C_{DELAY} —0.1 μF

$R_{PULL UP}$ —4.7k

Figure 24. Standard Test Circuits and Layout Guides

As in any switching regulator, layout is very important. Rapidly switching currents associated with wiring inductance can generate voltage transients which can cause problems. For minimal inductance and ground loops, the wires indicated by **heavy lines should be wide printed circuit traces and should be kept as short as possible**. For best results, external components should be located as close to the switcher IC as possible using ground plane construction or single point grounding.

If **open core inductors are used**, special care must be taken as to the location and positioning of this type of inductor. Allowing the inductor flux to intersect sensitive feedback, IC groundpath and C_{OUT} wiring can cause problems.

When using the adjustable version, special care must be taken as to the location of the feedback resistors and the associated wiring. Physically locate both resistors near the IC, and route the wiring away from the inductor, especially an open core type of inductor. (See [Application Information](#) section for more information.)

Table 1. LM2598 Series Buck Regulator Design Procedure (Fixed Output)

| PROCEDURE (Fixed Output Voltage Version) | EXAMPLE (Fixed Output Voltage Version) |
|--|--|
| Given: | Given: |
| V_{OUT} = Regulated Output Voltage (3.3V, 5V or 12V) | $V_{OUT} = 5V$ |
| $V_{IN(max)}$ = Maximum DC Input Voltage | $V_{IN(max)} = 12V$ |
| $I_{LOAD(max)}$ = Maximum Load Current | $I_{LOAD(max)} = 1A$ |
| 1. Inductor Selection (L1) | 1. Inductor Selection (L1) |
| A. Select the correct inductor value selection guide from Figures Figure 25 , Figure 26 , or Figure 27 (Output voltages of 3.3V, 5V, or 12V respectively.) For all other voltages, see the Design Procedure for the adjustable version. | A. Use the inductor selection guide for the 5V version shown in Figure 26 . |
| B. From the inductor value selection guide, identify the inductance region intersected by the Maximum Input Voltage line and the Maximum Load Current line. Each region is identified by an inductance value and an inductor code (LXX). | B. From the inductor value selection guide shown in Figure 26 , the inductance region intersected by the 12V horizontal line and the 1A vertical line is 68 μH , and the inductor code is L30. |
| C. Select an appropriate inductor from the four manufacturer's part numbers listed in Table 5 . | C. The inductance value required is 68 μH . From the table in Table 5 , go to the L30 line and choose an inductor part number from any of the four manufacturers shown. (In most instance, both through hole and surface mount inductors are available.) |
| 2. Output Capacitor Selection (C_{OUT}) | 2. Output Capacitor Selection (C_{OUT}) |
| A. In the majority of applications, low ESR (Equivalent Series Resistance) electrolytic capacitors between 47 μF and 330 μF and low ESR solid tantalum capacitors between 56 μF and 270 μF provide the best results. This capacitor should be located close to the IC using short capacitor leads and short copper traces. Do not use capacitors larger than 330 μF . For additional information, see section on output capacitors in Application Information section. | A. See section on output capacitors in Application Information section. |

Table 1. LM2598 Series Buck Regulator Design Procedure (Fixed Output) (continued)

| PROCEDURE (Fixed Output Voltage Version) | EXAMPLE (Fixed Output Voltage Version) |
|--|---|
| <p>B. To simplify the capacitor selection procedure, refer to the quick design component selection table shown in Figure 28. This table contains different input voltages, output voltages, and load currents, and lists various inductors and output capacitors that will provide the best design solutions.</p> | <p>B. From the quick design component selection table shown in Figure 28, locate the 5V output voltage section. In the load current column, choose the load current line that is closest to the current needed in your application, for this example, use the 1A line. In the maximum input voltage column, select the line that covers the input voltage needed in your application, in this example, use the 15V line. Continuing on this line are recommended inductors and capacitors that will provide the best overall performance.</p> <p>The capacitor list contains both through hole electrolytic and surface mount tantalum capacitors from four different capacitor manufacturers. It is recommended that both the manufacturers and the manufacturer's series that are listed in the table be used.</p> <p>In this example aluminum electrolytic capacitors from several different manufacturers are available with the range of ESR numbers needed.</p> <p style="text-align: center;">220 μF 25V Panasonic HFQ Series 220 μF 25V Nichicon PL Series</p> |
| <p>C. The capacitor voltage rating for electrolytic capacitors should be at least 1.5 times greater than the output voltage, and often much higher voltage ratings are needed to satisfy the low ESR requirements for low output ripple voltage</p> | <p>C. For a 5V output, a capacitor voltage rating at least 7.5V or more is needed. But, in this example, even a low ESR, switching grade, 220 μF 10V aluminum electrolytic capacitor would exhibit approximately 225 mΩ of ESR (see the curve in Figure 34 for the ESR vs voltage rating). This amount of ESR would result in relatively high output ripple voltage. To reduce the ripple to 1% of the output voltage, or less, a capacitor with a higher voltage rating (lower ESR) should be selected. A 16V or 25V capacitor will reduce the ripple voltage by approximately half.</p> |
| <p>D. For computer aided design software, see Switchers Made Simple™ (version 4.2 or later).</p> | |
| <p>3. Catch Diode Selection (D1)</p> | <p>3. Catch Diode Selection (D1)</p> |
| <p>A. The catch diode current rating must be at least 1.3 times greater than the maximum load current. Also, if the power supply design must withstand a continuous output short, the diode should have a current rating equal to the maximum current limit of the LM2598. The most stressful condition for this diode is an overload or shorted output condition.</p> | <p>A. Refer to the table shown in Table 8. In this example, a 3A, 20V, 1N5820 Schottky diode will provide the best performance, and will not be overstressed even for a shorted output.</p> |
| <p>B. The reverse voltage rating of the diode should be at least 1.25 times the maximum input voltage.</p> | |
| <p>C. This diode must be fast (short reverse recovery time) and must be located close to the LM2598 using short leads and short printed circuit traces. Because of their fast switching speed and low forward voltage drop, Schottky diodes provide the best performance and efficiency, and should be the first choice, especially in low output voltage applications. Ultra-fast recovery, or High-Efficiency rectifiers also provide good results. Ultra-fast recovery diodes typically have reverse recovery times of 50 ns or less. Rectifiers such as the 1N5400 series are much too slow and should not be used.</p> | |

Table 1. LM2598 Series Buck Regulator Design Procedure (Fixed Output) (continued)

| PROCEDURE (Fixed Output Voltage Version) | EXAMPLE (Fixed Output Voltage Version) |
|---|---|
| <p>4. Input Capacitor (C_{IN})</p> <p>A low ESR aluminum or tantalum bypass capacitor is needed between the input pin and ground to prevent large voltage transients from appearing at the input. In addition, the RMS current rating of the input capacitor should be selected to be at least $\frac{1}{2}$ the DC load current. The capacitor manufacturers data sheet must be checked to assure that this current rating is not exceeded. The curve shown in Figure 33 shows typical RMS current ratings for several different aluminum electrolytic capacitor values.</p> <p>This capacitor should be located close to the IC using short leads and the voltage rating should be approximately 1.5 times the maximum input voltage.</p> <p>If solid tantalum input capacitors are used, it is recommended that they be surge current tested by the manufacturer.</p> <p>Use caution when using ceramic capacitors for input bypassing, because it may cause severe ringing at the V_{IN} pin.</p> <p>For additional information, see section on input capacitors in Application Information section.</p> | <p>4. Input Capacitor (C_{IN})</p> <p>The important parameters for the Input capacitor are the input voltage rating and the RMS current rating. With a nominal input voltage of 12V, an aluminum electrolytic capacitor with a voltage rating greater than 18V ($1.5 \times V_{IN}$) would be needed. The next higher capacitor voltage rating is 25V.</p> <p>The RMS current rating requirement for the input capacitor in a buck regulator is approximately $\frac{1}{2}$ the DC load current. In this example, with a 1A load, a capacitor with a RMS current rating of at least 500 mA is needed. The curves shown in Figure 33 can be used to select an appropriate input capacitor. From the curves, locate the 25V line and note which capacitor values have RMS current ratings greater than 500 mA. Either a 180 μF or 220 μF, 25V capacitor could be used.</p> <p>For a through hole design, a 220 μF/25V electrolytic capacitor (Panasonic HFQ series or Nichicon PL series or equivalent) would be adequate. Other types or other manufacturers capacitors can be used provided the RMS ripple current ratings are adequate.</p> <p>For surface mount designs, solid tantalum capacitors are recommended. The TPS series available from AVX, and the 593D series from Sprague are both surge current tested.</p> |

Table 2. LM2598 Fixed Voltage Quick Design Component Selection Table

| Conditions | | | Inductor | | Output Capacitor | | | |
|--------------------|------------------|-----------------------|-----------------------|--------------|-----------------------------------|---------------------------------|-----------------------------|----------------------------------|
| Output Voltage (V) | Load Current (A) | Max Input Voltage (V) | Inductance (μ H) | Inductor (#) | Through Hole Electrolytic | | Surface Mount Tantalum | |
| | | | | | Panasonic HFQ Series (μ F/V) | Nichicon PL Series (μ F/V) | AVX TPS Series (μ F/V) | Sprague 595D Series (μ F/V) |
| 3.3 | 1 | 5 | 22 | L24 | 330/16 | 330/16 | 220/10 | 330/10 |
| | | 7 | 33 | L23 | 270/25 | 270/25 | 220/10 | 270/10 |
| | | 10 | 47 | L31 | 220/25 | 220/35 | 220/10 | 220/10 |
| | | 40 | 68 | L30 | 180/35 | 220/35 | 220/10 | 180/10 |
| | 0.5 | 6 | 47 | L13 | 220/25 | 220/16 | 220/16 | 220/10 |
| | | 10 | 68 | L21 | 150/35 | 150/25 | 100/16 | 150/16 |
| 5 | 1 | 40 | 100 | L20 | 150/35 | 82/35 | 100/16 | 100/20 |
| | | 8 | 33 | L28 | 330/16 | 330/16 | 220/10 | 270/10 |
| | | 10 | 47 | L31 | 220/25 | 220/25 | 220/10 | 220/10 |
| | | 15 | 68 | L30 | 180/35 | 180/35 | 220/10 | 150/16 |
| | 0.5 | 40 | 100 | L29 | 180/35 | 120/35 | 100/16 | 120/16 |
| | | 9 | 68 | L21 | 180/16 | 180/16 | 220/10 | 150/16 |
| 12 | 1 | 20 | 150 | L19 | 120/25 | 120/25 | 100/16 | 100/20 |
| | | 40 | 150 | L19 | 100/25 | 100/25 | 68/20 | 68/25 |
| | | 15 | 47 | L31 | 220/25 | 220/25 | 68/20 | 120/20 |
| | | 18 | 68 | L30 | 180/35 | 120/25 | 68/20 | 120/20 |
| | 0.5 | 30 | 150 | L36 | 82/25 | 82/25 | 68/20 | 100/20 |
| | | 40 | 220 | L35 | 82/25 | 82/25 | 68/20 | 68/25 |
| 0.5 | 15 | 68 | L21 | 180/25 | 180/25 | 68/20 | 120/20 | |
| | 20 | 150 | L19 | 82/25 | 82/25 | 68/20 | 100/20 | |
| | | 40 | 330 | L26 | 56/25 | 56/25 | 68/20 | 68/25 |

Table 3. LM2598 Series Buck Regulator Design Procedure (Adjustable Output)

| PROCEDURE (Adjustable Output Voltage Version) | EXAMPLE (Adjustable Output Voltage Version) |
|---|--|
| <p>Given: V_{OUT} = Regulated Output Voltage $V_{IN(max)}$ = Maximum Input Voltage $I_{LOAD(max)}$ = Maximum Load Current F = Switching Frequency (<i>Fixed at a nominal 150 kHz</i>).</p> | <p>Given: $V_{OUT} = 20V$ $V_{IN(max)} = 28V$ $I_{LOAD(max)} = 1A$ F = Switching Frequency (<i>Fixed at a nominal 150 kHz</i>).</p> |
| <p>1. Programming Output Voltage (Selecting R_1 and R_2, as shown in Figure 24) Use the following formula to select the appropriate resistor values.</p> $V_{OUT} = V_{REF} \left(1 + \frac{R_2}{R_1} \right) \quad \text{where } V_{REF} = 1.23V \quad (1)$ <p>Select a value for R_1 between 240Ω and 1.5 kΩ. The lower resistor values minimize noise pickup in the sensitive feedback pin. (For the lowest temperature coefficient and the best stability with time, use 1% metal film resistors.)</p> $R_2 = R_1 \left(\frac{V_{OUT}}{V_{REF}} - 1 \right) \quad (2)$ | <p>1. Programming Output Voltage (Selecting R_1 and R_2, as shown in Figure 24) Select R_1 to be 1 kΩ, 1%. Solve for R_2.</p> $R_2 = R_1 \left(\frac{V_{OUT}}{V_{REF}} - 1 \right) = 1k \left(\frac{20V}{1.23V} - 1 \right) \quad (3)$ <p>$R_2 = 1k (16.26 - 1) = 15.26k$, closest 1% value is 15.4 kΩ. $R_2 = 15.4 k\Omega$.</p> |
| <p>2. Inductor Selection (L1) A. Calculate the inductor Volt • microsecond constant $E \cdot T$ ($V \cdot \mu s$), from the following formula:</p> $E \cdot T = (V_{IN} - V_{OUT} - V_{SAT}) \cdot \frac{V_{OUT} + V_D}{V_{IN} - V_{SAT} + V_D} \cdot \frac{1000}{150 \text{ kHz}} \quad (V \cdot \mu s)$ <p>where</p> <ul style="list-style-type: none"> V_{SAT} = internal switch saturation voltage = 1V V_D = diode forward voltage drop = 0.5V <p style="text-align: right;">(4)</p> | <p>2. Inductor Selection (L1) A. Calculate the inductor Volt • microsecond constant ($E \cdot T$),</p> $E \cdot T = (28 - 20 - 1) \cdot \frac{20 + 0.5}{28 - 1 + 0.5} \cdot \frac{1000}{150} \quad (V \cdot \mu s)$ $E \cdot T = (7) \cdot \frac{20.5}{27.6} \cdot 6.67 \quad (V \cdot \mu s) = 34.8 \quad (V \cdot \mu s) \quad (5)$ |
| <p>B. Use the $E \cdot T$ value from the previous formula and match it with the $E \cdot T$ number on the vertical axis of the Inductor Value Selection Guide shown in INDUCTOR VALUE SELECTION GUIDES.</p> | <p>B. $E \cdot T = 34.8 \quad (V \cdot \mu s)$</p> |
| <p>C. on the horizontal axis, select the maximum load current.</p> | <p>C. $I_{LOAD(max)} = 1A$</p> |
| <p>D. Identify the inductance region intersected by the $E \cdot T$ value and the Maximum Load Current value. Each region is identified by an inductance value and an inductor code (LXX).</p> | <p>D. From the inductor value selection guide shown in INDUCTOR VALUE SELECTION GUIDES, the inductance region intersected by the 35 ($V \cdot \mu s$) horizontal line and the 1A vertical line is 100 μH, and the inductor code is L29.</p> |
| <p>E. Select an appropriate inductor from the four manufacturer's part numbers listed in Table 5.</p> | <p>E. From the table in Table 5, locate line L29, and select an inductor part number from the list of manufacturers part numbers.</p> |
| <p>3. Output Capacitor Selection (C_{OUT}) A. In the majority of applications, low ESR electrolytic or solid tantalum capacitors between 82 μF and 220 μF provide the best results. This capacitor should be located close to the IC using short capacitor leads and short copper traces. Do not use capacitors larger than 220 μF. For additional information, see section on output capacitors in Application Information section.</p> | <p>3. Output Capacitor Selection (C_{OUT}) A. See section on C_{OUT} in Application Information section.</p> |

Table 3. LM2598 Series Buck Regulator Design Procedure (Adjustable Output) (continued)

| PROCEDURE (Adjustable Output Voltage Version) | EXAMPLE (Adjustable Output Voltage Version) |
|--|---|
| <p>B. To simplify the capacitor selection procedure, refer to the quick design table shown in Table 4. This table contains different output voltages, and lists various output capacitors that will provide the best design solutions.</p> | <p>B. From the quick design table shown in Table 4, locate the output voltage column. From that column, locate the output voltage closest to the output voltage in your application. In this example, select the 24V line. Under the OUTPUT CAPACITOR section, select a capacitor from the list of through hole electrolytic or surface mount tantalum types from four different capacitor manufacturers. It is recommended that both the manufacturers and the manufacturers series that are listed in the table be used.</p> <p>In this example, through hole aluminum electrolytic capacitors from several different manufacturers are available.</p> <p style="padding-left: 40px;">82 μF 35V Panasonic HFQ Series 82 μF 35V Nichicon PL Series</p> |
| <p>C. The capacitor voltage rating should be at least 1.5 times greater than the output voltage, and often much higher voltage ratings are needed to satisfy the low ESR requirements needed for low output ripple voltage.</p> | <p>C. For a 20V output, a capacitor rating of at least 30V or more is needed. In this example, either a 35V or 50V capacitor would work. A 35V rating was chosen although a 50V rating could also be used if a lower output ripple voltage is needed.</p> <p>Other manufacturers or other types of capacitors may also be used, provided the capacitor specifications (especially the 100 kHz ESR) closely match the types listed in the table. Refer to the capacitor manufacturers data sheet for this information.</p> |
| <p>4. Feedforward Capacitor (C_{FF}) (See Figure 24)</p> <p>For output voltages greater than approximately 10V, an additional capacitor is required. The compensation capacitor is typically between 50 pF and 10 nF, and is wired in parallel with the output voltage setting resistor, R_2. It provides additional stability for high output voltages, low input-output voltages, and/or very low ESR output capacitors, such as solid tantalum capacitors.</p> $C_{FF} = \frac{1}{31 \times 10^3 \times R_2} \quad (6)$ <p>This capacitor type can be ceramic, plastic, silver mica, etc. (Because of the unstable characteristics of ceramic capacitors made with Z5U material, they are not recommended.)</p> | <p>4. Feedforward Capacitor (C_{FF})</p> <p>The table shown in Table 4 contains feed forward capacitor values for various output voltages. In this example, a 1 nF capacitor is needed.</p> |
| <p>5. Catch Diode Selection (D1)</p> <p>A. The catch diode current rating must be at least 1.3 times greater than the maximum load current. Also, if the power supply design must withstand a continuous output short, the diode should have a current rating equal to the maximum current limit of the LM2598. The most stressful condition for this diode is an overload or shorted output condition.</p> <p>B. The reverse voltage rating of the diode should be at least 1.25 times the maximum input voltage.</p> <p>C. This diode must be fast (short reverse recovery time) and must be located close to the LM2598 using short leads and short printed circuit traces. Because of their fast switching speed and low forward voltage drop, Schottky diodes provide the best performance and efficiency, and should be the first choice, especially in low output voltage applications. Ultra-fast recovery, or High-Efficiency rectifiers are also a good choice, but some types with an abrupt turn-off characteristic may cause instability or EMI problems. Ultra-fast recovery diodes typically have reverse recovery times of 50 ns or less. Rectifiers such as the 1N4001 series are much too slow and should not be used.</p> | <p>5. Catch Diode Selection (D1)</p> <p>A. Refer to the table shown in Table 8. Schottky diodes provide the best performance, and in this example a 3A, 40V, 1N5822 Schottky diode would be a good choice. The 3A diode rating is more than adequate and will not be overstressed even for a shorted output.</p> |

Table 3. LM2598 Series Buck Regulator Design Procedure (Adjustable Output) (continued)

| PROCEDURE (Adjustable Output Voltage Version) | EXAMPLE (Adjustable Output Voltage Version) |
|--|---|
| <p>6. Input Capacitor (C_{IN})</p> <p>A low ESR aluminum or tantalum bypass capacitor is needed between the input pin and ground to prevent large voltage transients from appearing at the input. In addition, the RMS current rating of the input capacitor should be selected to be at least ½ the DC load current. The capacitor manufacturers data sheet must be checked to assure that this current rating is not exceeded. The curve shown in Figure 33 shows typical RMS current ratings for several different aluminum electrolytic capacitor values.</p> <p>This capacitor should be located close to the IC using short leads and the voltage rating should be approximately 1.5 times the maximum input voltage.</p> <p>If solid tantalum input capacitors are used, it is recommended that they be surge current tested by the manufacturer.</p> <p>Use caution when using a high dielectric constant ceramic capacitor for input bypassing, because it may cause severe ringing at the V_{IN} pin.</p> | <p>6. Input Capacitor (C_{IN})</p> <p>The important parameters for the Input capacitor are the input voltage rating and the RMS current rating. With a nominal input voltage of 28V, an aluminum electrolytic aluminum electrolytic capacitor with a voltage rating greater than 42V (1.5 × V_{IN}) would be needed. Since the the next higher capacitor voltage rating is 50V, a 50V capacitor should be used. The capacitor voltage rating of (1.5 × V_{IN}) is a conservative guideline, and can be modified somewhat if desired.</p> <p>The RMS current rating requirement for the input capacitor of a buck regulator is approximately ½ the DC load current. In this example, with a 1A load, a capacitor with a RMS current rating of at least 500 mA is needed.</p> <p>The curves shown in Figure 33 can be used to select an appropriate input capacitor. From the curves, locate the 50V line and note which capacitor values have RMS current ratings greater than 500 mA. Either a 100 μF or 120 μF, 50V capacitor could be used.</p> <p>For a through hole design, a 120 μF/50V electrolytic capacitor (Panasonic HFQ series or Nichicon PL series or equivalent) would be adequate. Other types or other manufacturers capacitors can be used provided the RMS ripple current ratings are adequate.</p> <p>For surface mount designs, solid tantalum capacitors can be used, but caution must be exercised with regard to the capacitor surge current rating (see Application Information or INPUT CAPACITOR in this data sheet). The TPS series available from AVX, and the 593D series from Sprague are both surge current tested.</p> |
| <p>For additional information, see section on input capacitor in Application Information section.</p> | <p>To further simplify the buck regulator design procedure, Texas Instruments is making available computer design software to be used with the Simple Switcher line of switching regulators. Switchers Made Simple (version 4.2 or later) is available on a 3½" diskette for IBM compatible computers.</p> |

Table 4. Output Capacitor and Feedforward Capacitor Selection Table

| Output Voltage (V) | Through Hole Electrolytic Output Capacitor | | | Surface Mount Tantalum Output Capacitor | | |
|--------------------|--|---------------------------|-----------------------|---|----------------------------|-----------------------|
| | Panasonic HFQ Series (μF/V) | Nichicon PL Series (μF/V) | Feedforward Capacitor | AVX TPS Series (μF/V) | Sprague 595D Series (μF/V) | Feedforward Capacitor |
| 1.2 | 330/50 | 330/50 | 0 | 330/6.3 | 330/6.3 | 0 |
| 4 | 220/25 | 220/25 | 4.7 nF | 220/10 | 220/10 | 4.7 nF |
| 6 | 220/25 | 220/25 | 3.3 nF | 220/10 | 220/10 | 3.3 nF |
| 9 | 180/25 | 180/25 | 1.5 nF | 100/16 | 180/16 | 1.5 nF |
| 12 | 120/25 | 120/25 | 1.5 nF | 68/20 | 120/20 | 1.5 nF |
| 15 | 120/25 | 120/25 | 1.5 nF | 68/20 | 100/20 | 1.5 nF |
| 24 | 82/35 | 82/35 | 1 nF | 33/25 | 33/35 | 220 pF |
| 28 | 82/50 | 82/50 | 1 nF | 10/35 | 33/35 | 220 pF |

LM2598 Series Buck Regulator Design Procedure

INDUCTOR VALUE SELECTION GUIDES

(For Continuous Mode Operation)

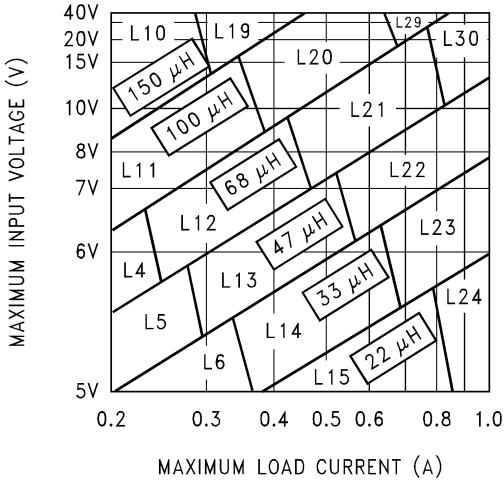

Figure 25. LM2598-3.3

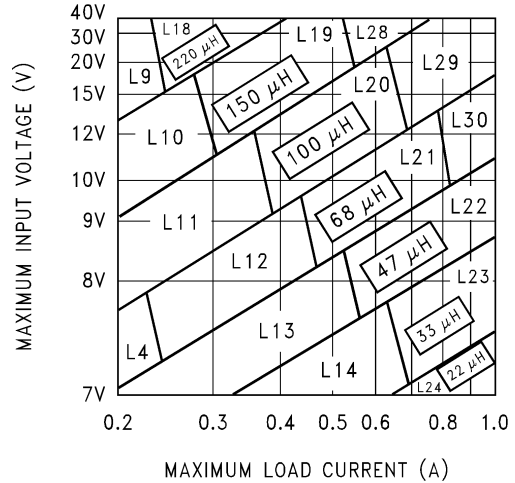

Figure 26. LM2598-5.0

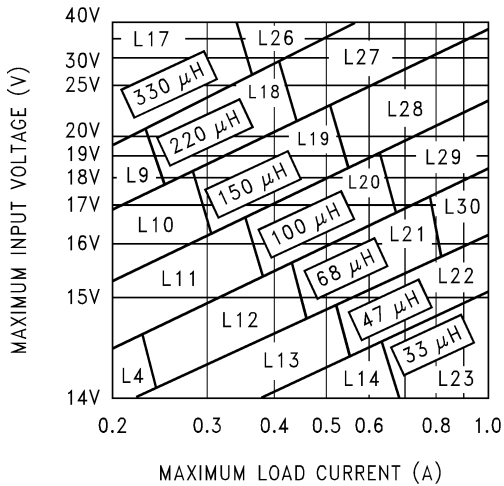

Figure 27. LM2598-12

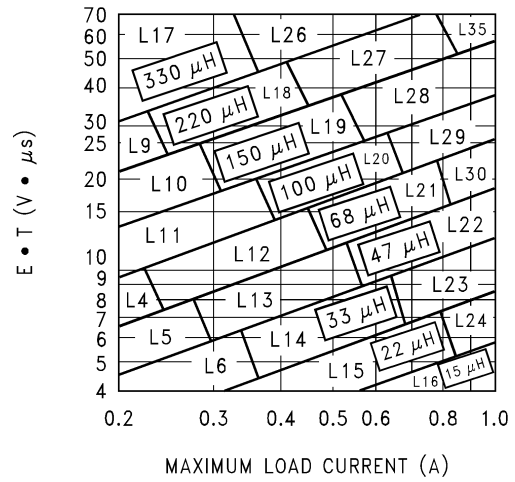

Figure 28. LM2598-ADJ

Table 5. Inductor Manufacturers Part Numbers

| | Inductance (μH) | Current (A) | Schott | | Renco | | Pulse Engineering | | Coilcraft |
|-----|-----------------|-------------|--------------|---------------|---------------|---------------|-------------------|---------------|---------------|
| | | | Through Hole | Surface Mount | Through Hole | Surface Mount | Through Hole | Surface Mount | Surface Mount |
| L4 | 68 | 0.32 | 67143940 | 67144310 | RL-1284-68-43 | RL1500-68 | PE-53804 | PE-53804-S | DO1608-68 |
| L5 | 47 | 0.37 | 67148310 | 67148420 | RL-1284-47-43 | RL1500-47 | PE-53805 | PE-53805-S | DO1608-473 |
| L6 | 33 | 0.44 | 67148320 | 67148430 | RL-1284-33-43 | RL1500-33 | PE-53806 | PE-53806-S | DO1608-333 |
| L9 | 220 | 0.32 | 67143960 | 67144330 | RL-5470-3 | RL1500-220 | PE-53809 | PE-53809-S | DO3308-224 |
| L10 | 150 | 0.39 | 67143970 | 67144340 | RL-5470-4 | RL1500-150 | PE-53810 | PE-53810-S | DO3308-154 |
| L11 | 100 | 0.48 | 67143980 | 67144350 | RL-5470-5 | RL1500-100 | PE-53811 | PE-53811-S | DO3308-104 |
| L12 | 68 | 0.58 | 67143990 | 67144360 | RL-5470-6 | RL1500-68 | PE-53812 | PE-53812-S | DO3308-683 |
| L13 | 47 | 0.70 | 67144000 | 67144380 | RL-5470-7 | RL1500-47 | PE-53813 | PE-53813-S | DO3308-473 |
| L14 | 33 | 0.83 | 67148340 | 67148450 | RL-1284-33-43 | RL1500-33 | PE-53814 | PE-53814-S | DO3308-333 |

Table 5. Inductor Manufacturers Part Numbers (continued)

| | Inductance (μ H) | Current (A) | Schott | | Renco | | Pulse Engineering | | Coilcraft |
|-----|--------------------------|----------------|-----------------|------------------|-----------------|------------------|-------------------|------------------|------------------|
| | | | Through Hole | Surface Mount | Through Hole | Surface Mount | Through Hole | Surface Mount | Surface Mount |
| L15 | 22 | 0.99 | 67148350 | 67148460 | RL-1284-22-43 | RL1500-22 | PE-53815 | PE-53815-S | DO3308-223 |
| L16 | 15 | 1.24 | 67148360 | 67148470 | RL-1284-15-43 | RL1500-15 | PE-53816 | PE-53816-S | DO3308-153 |
| L17 | 330 | 0.42 | 67144030 | 67144410 | RL-5471-1 | RL1500-330 | PE-53817 | PE-53817-S | DO3316-334 |
| L18 | 220 | 0.55 | 67144040 | 67144420 | RL-5471-2 | RL1500-220 | PE-53818 | PE-53818-S | DO3316-224 |
| L19 | 150 | 0.66 | 67144050 | 67144430 | RL-5471-3 | RL1500-150 | PE-53819 | PE-53819-S | DO3316-154 |
| L20 | 100 | 0.82 | 67144060 | 67144440 | RL-5471-4 | RL1500-100 | PE-53820 | PE-53820-S | DO3316-104 |
| L21 | 68 | 0.99 | 67144070 | 67144450 | RL-5471-5 | RL1500-68 | PE-53821 | PE-53821-S | DO3316-683 |
| L22 | 47 | 1.17 | 67144080 | 67144460 | RL-5471-6 | — | PE-53822 | PE-53822-S | DO3316-473 |
| L23 | 33 | 1.40 | 67144090 | 67144470 | RL-5471-7 | — | PE-53823 | PE-53823-S | DO3316-333 |
| L24 | 22 | 1.70 | 67148370 | 67144480 | RL-1283-22-43 | — | PE-53824 | PE-53824-S | DO3316-223 |
| L26 | 330 | 0.80 | 67144100 | 67144480 | RL-5471-1 | — | PE-53826 | PE-53826-S | DO5022P-334 |
| L27 | 220 | 1.00 | 67144110 | 67144490 | RL-5471-2 | — | PE-53827 | PE-53827-S | DO5022P-224 |
| L28 | 150 | 1.20 | 67144120 | 67144500 | RL-5471-3 | — | PE-53828 | PE-53828-S | DO5022P-154 |
| L29 | 100 | 1.47 | 67144130 | 67144510 | RL-5471-4 | — | PE-53829 | PE-53829-S | DO5022P-104 |
| L30 | 68 | 1.78 | 67144140 | 67144520 | RL-5471-5 | — | PE-53830 | PE-53830-S | DO5022P-683 |
| L35 | 47 | 2.15 | 67144170 | — | RL-5473-1 | — | PE-53935 | PE-53935-S | — |

Table 6. Inductor Manufacturers Phone Numbers

| | | |
|---|-------|------------------|
| Coilcraft Inc. | Phone | (800) 322-2645 |
| | FAX | (708) 639-1469 |
| Coilcraft Inc., Europe | Phone | +11 1236 730 595 |
| | FAX | +44 1236 730 627 |
| Pulse Engineering Inc. | Phone | (619) 674-8100 |
| | FAX | (619) 674-8262 |
| Pulse Engineering Inc., Europe | Phone | +353 93 24 107 |
| | FAX | +353 93 24 459 |
| Renco Electronics Inc. | Phone | (800) 645-5828 |
| | FAX | (516) 586-5562 |
| Schott Corp. | Phone | (612) 475-1173 |
| | FAX | (612) 475-1786 |

Table 7. Capacitor Manufacturers Phone Numbers

| | | |
|-----------------------|-------|----------------|
| Nichicon Corp. | Phone | (708) 843-7500 |
| | FAX | (708) 843-2798 |
| Panasonic | Phone | (714) 373-7857 |
| | FAX | (714) 373-7102 |
| AVX Corp. | Phone | (803) 448-9411 |
| | FAX | (803) 448-1943 |
| Sprague/Vishay | Phone | (207) 324-4140 |
| | FAX | (207) 324-7223 |

Table 8. Diode Selection Table

| VR | 1A Diodes | | | | 3A Diodes | | | |
|-------------|---------------|--|--------------|--|---------------|--|--------------|--|
| | Surface Mount | | Through Hole | | Surface Mount | | Through Hole | |
| | Schottky | Ultra Fast | Schottky | Ultra Fast | Schottky | Ultra Fast | Schottky | Ultra Fast |
| | | Recovery | | Recovery | | Recovery | | Recovery |
| 20V | SK12 | All of these diodes are rated to at least 50V. | 1N5817 | All of these diodes are rated to at least 50V. | | All of these diodes are rated to at least 50V. | IN5820 | All of these diodes are rated to at least 50V. |
| | | | SR102 | | SK32 | | SR302 | |
| | | | | | | | MBR320 | |
| 30V | SK13 | | 1N5818 | | | | 1N5821 | |
| | MBRS130 | | SR103 | | SK33 | | MBR330 | |
| | | | 11DQ03 | | | | 31DQ03 | |
| 40V | SK14 | | | | | | 1N5822 | |
| | MBRS140 | | 1N5819 | | SK34 | | SR304 | |
| | 10BQ040 | | SR104 | | MBRS340 | | MBR340 | |
| | 10MQ040 | MURS120 | 11DQ04 | MUR120 | 30WQ04 | MURS320 | 31DQ04 | MUR320 |
| 50V or more | MBRS160 | 10BF10 | SR105 | | SK35 | 30WF10 | SR305 | 30WF10 |
| | 10BQ050 | | MBR150 | | MBRS360 | | MBR350 | |
| | 10MQ060 | | 11DQ05 | | 30WQ05 | | 31DQ05 | |

Block Diagram

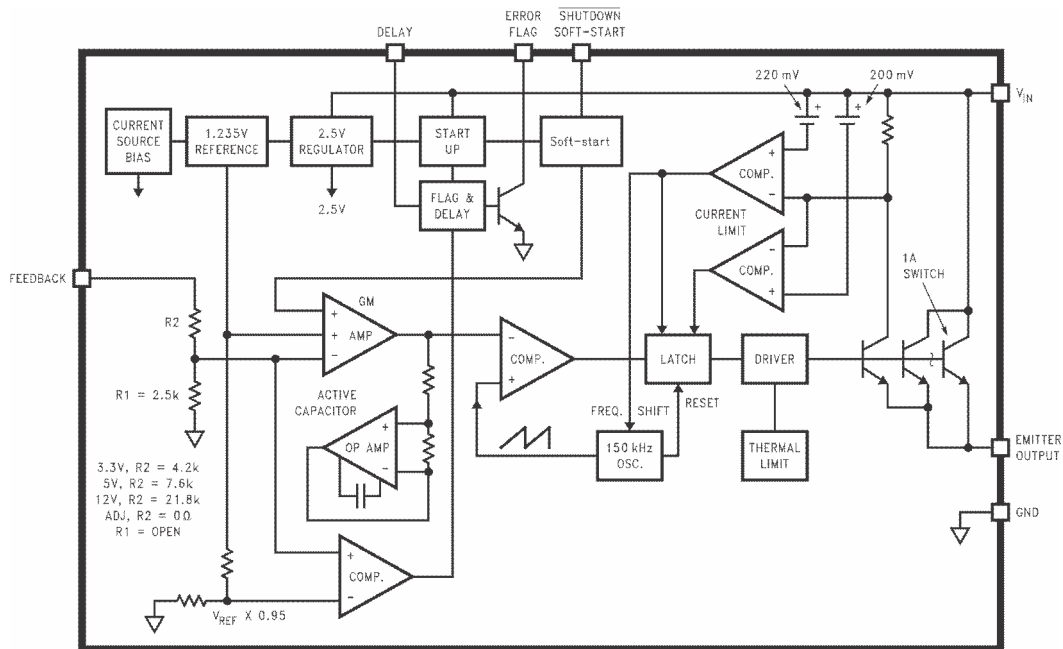

Figure 29.

APPLICATION INFORMATION

Table 9. PIN DESCRIPTIONS

| Name | Description |
|-------------------------------------|---|
| +V_{IN} (Pin 2) | This is the positive input supply for the IC switching regulator. A suitable input bypass capacitor must be present at this pin to minimize voltage transients and to supply the switching currents needed by the regulator. |
| Ground (Pin 4) | Circuit ground. |
| Output (Pin 1) | Internal switch. The voltage at this pin switches between approximately (+V _{IN} – V _{SAT}) and approximately –0.5V, with a duty cycle of V _{OUT} /V _{IN} . To minimize coupling to sensitive circuitry, the PC board copper area connected to this pin should be kept to a minimum. |
| Feedback (Pin 6) | Senses the regulated output voltage to complete the feedback loop. |
| Shutdown /Soft-start (Pin 7) | This dual function pin provides the following features: (a) Allows the switching regulator circuit to be shut down using logic level signals thus dropping the total input supply current to approximately 85 μA. (b) Adding a capacitor to this pin provides a soft-start feature which minimizes startup current and provides a controlled ramp up of the output voltage. |
| Error Flag (Pin 3) | Open collector output that provides a low signal (flag transistor ON) when the regulated output voltage drops more than 5% from the nominal output voltage. On start up, Error Flag is low until V _{OUT} reaches 95% of the nominal output voltage and a delay time determined by the Delay pin capacitor. This signal can be used as a reset to a microprocessor on power-up. |
| Delay (Pin 5) | At power-up, this pin can be used to provide a time delay between the time the regulated output voltage reaches 95% of the nominal output voltage, and the time the error flag output goes high. |
| Special Note | If any of the above three features (Shutdown /Soft-start, Error Flag, or Delay) are not used, the respective pins should be left open. |

EXTERNAL COMPONENTS

SOFT-START CAPACITOR

C_{SS} — A capacitor on this pin provides the regulator with a Soft-start feature (slow start-up). When the DC input voltage is first applied to the regulator, or when the Shutdown /Soft-start pin is allowed to go high, a constant current (approximately 5 μA) begins charging this capacitor. As the capacitor voltage rises, the regulator goes through four operating regions (See the bottom curve in [Figure 30](#)).

- Regulator in Shutdown.** When the \overline{SD} /SS pin voltage is between 0V and 1.3V, the regulator is in shutdown, the output voltage is zero, and the IC quiescent current is approximately 85 μA.
- Regulator ON, but the output voltage is zero.** With the \overline{SD} /SS pin voltage between approximately 1.3V and 1.8V, the internal regulator circuitry is operating, the quiescent current rises to approximately 5 mA, but the output voltage is still zero. Also, as the 1.3V threshold is exceeded, the Soft-start capacitor charging current decreases from 5 μA down to approximately 1.6 μA. This decreases the slope of capacitor voltage ramp.
- Soft-start Region.** When the \overline{SD} /SS pin voltage is between 1.8V and 2.8V (@ 25°C), the regulator is in a Soft-start condition. The switch (Pin 1) duty cycle initially starts out very low, with narrow pulses and gradually get wider as the capacitor \overline{SD} /SS pin ramps up towards 2.8V. As the duty cycle increases, the output voltage also increases at a controlled ramp up. See the center curve in [Figure 30](#). The input supply current requirement also starts out at a low level for the narrow pulses and ramp up in a controlled manner. This is a very useful feature in some switcher topologies that require large startup currents (such as the inverting configuration) which can load down the input power supply.

Note: The lower curve shown in [Figure 30](#) shows the Soft-start region from 0% to 100%. This is not the duty cycle percentage, but the output voltage percentage. Also, the Soft-start voltage range has a negative temperature coefficient associated with it. See the Soft-start curve in the [Electrical Characteristics](#) section.

- Normal operation.** Above 2.8V, the circuit operates as a standard Pulse Width Modulated switching regulator. The capacitor will continue to charge up until it reaches the internal clamp voltage of approximately 7V. If this pin is driven from a voltage source, the current must be limited to about 1 mA.

If the part is operated with an input voltage at or below the internal soft-start clamp voltage of approximately 7V, the voltage on the SD/SS pin tracks the input voltage and can be disturbed by a step in the voltage. To maintain proper function under these conditions, it is strongly recommended that the SD/SS pin be clamped externally between the 3V maximum soft-start threshold and the 4.5V minimum input voltage. Figure 32 is an example of an external 3.7V (approx.) clamp that prevents a line-step related glitch but does not interfere with the soft-start behavior of the device.

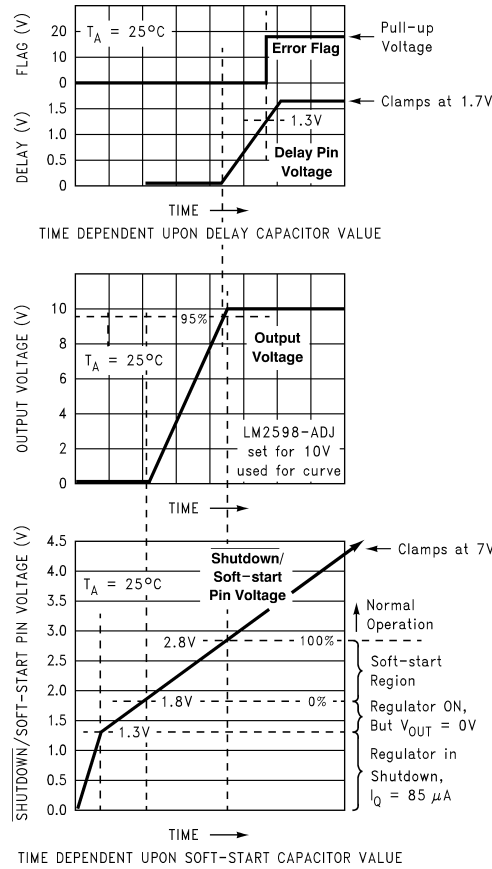

Figure 30. Soft-start, Delay, Error, Output

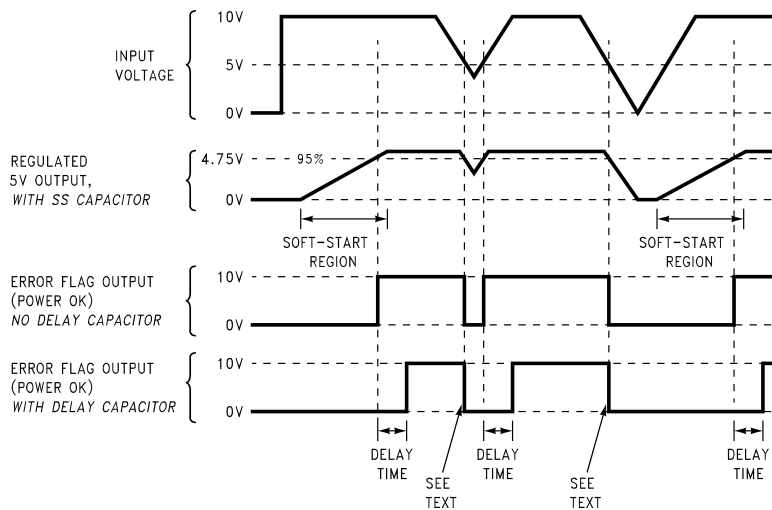

Figure 31. Timing Diagram for 5V Output

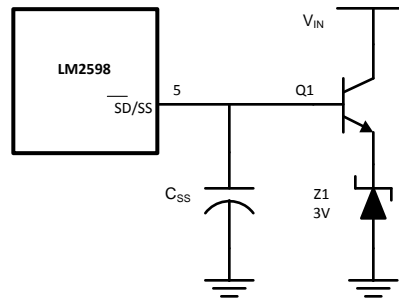

Figure 32. External 3.7V Soft-Start Clamp

DELAY CAPACITOR

C_{DELAY} — Provides delay for the error flag output. See the upper curve in [Figure 30](#), and also refer to timing diagrams in [Figure 31](#). A capacitor on this pin provides a time delay between the time the regulated output voltage (when it is increasing in value) reaches 95% of the nominal output voltage, and the time the error flag output goes high. A 3 μ A constant current from the delay pin charges the delay capacitor resulting in a voltage ramp. When this voltage reaches a threshold of approximately 1.3V, the open collector error flag output (or power OK) goes high. This signal can be used to indicate that the regulated output has reached the correct voltage and has stabilized.

If, for any reason, the regulated output voltage drops by 5% or more, the error output flag (Pin 3) immediately goes low (internal transistor turns on). The delay capacitor provides very little delay if the regulated output is dropping out of regulation. The delay time for an output that is decreasing is approximately a 1000 times less than the delay for the rising output. For a 0.1 μ F delay capacitor, the delay time would be approximately 50 ms when the output is rising and passes through the 95% threshold, but the delay for the output dropping would only be approximately 50 μ s.

R_{Pull Up} —The error flag output, (or power OK) is the collector of a NPN transistor, with the emitter internally grounded. To use the error flag, a pullup resistor to a positive voltage is needed. The error flag transistor is rated up to a maximum of 45V and can sink approximately 3 mA. If the error flag is not used, it can be left open.

FEEDFORWARD CAPACITOR

(Adjustable Output Voltage Version)

C_{FF} — A Feedforward Capacitor C_{FF}, shown across R2 in [Figure 24](#) is used when the output voltage is greater than 10V or then C_{OUT} has a very low ESR. This capacitor adds lead compensation to the feedback loop and increases the phase margin for better loop stability. For C_{FF} selection, see the [Design Procedure](#) section.

If the output ripple is large (> 5% of the nominal output voltage), this ripple can be coupled to the feedback pin through the feedforward capacitor and cause the error comparator to trigger the error flag. In this situation, adding a resistor, R_{FF}, in series with the feedforward capacitor, approximately 3 times R1, will attenuate the ripple voltage at the feedback pin.

INPUT CAPACITOR

C_{IN} — A low ESR aluminum or tantalum bypass capacitor is needed between the input pin and ground pin. It must be located near the regulator using short leads. This capacitor prevents large voltage transients from appearing at the input, and provides the instantaneous current needed each time the switch turns on.

The important parameters for the Input capacitor are the voltage rating and the RMS current rating. Because of the relatively high RMS currents flowing in a buck regulator's input capacitor, this capacitor should be chosen for its RMS current rating rather than its capacitance or voltage ratings, although the capacitance value and voltage rating are directly related to the RMS current rating.

The RMS current rating of a capacitor could be viewed as a capacitor's power rating. The RMS current flowing through the capacitor's internal ESR produces power which causes the internal temperature of the capacitor to rise. The RMS current rating of a capacitor is determined by the amount of current required to raise the internal temperature approximately 10°C above an ambient temperature of 105°C. The ability of the capacitor to dissipate this heat to the surrounding air will determine the amount of current the capacitor can safely sustain. Capacitors that are physically large and have a large surface area will typically have higher RMS current ratings. For a given capacitor value, a higher voltage electrolytic capacitor will be physically larger than a lower voltage capacitor, and thus be able to dissipate more heat to the surrounding air, and therefore will have a higher RMS current rating.

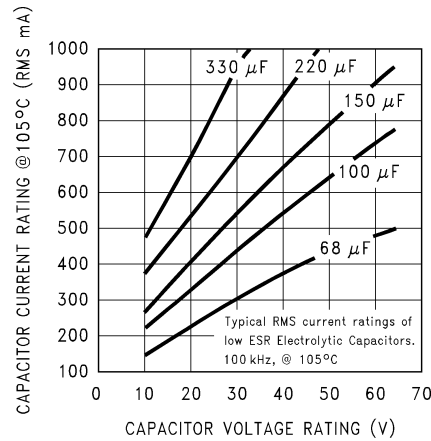

Figure 33. RMS Current Ratings for Low ESR Electrolytic Capacitors (Typical)

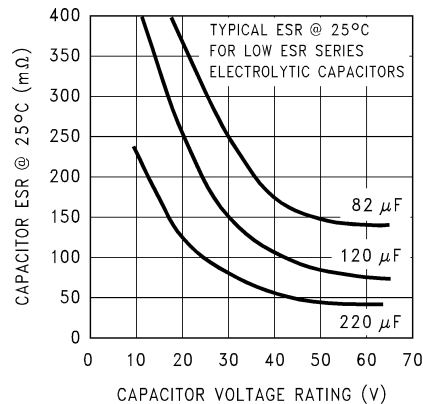

Figure 34. Capacitor ESR vs Capacitor Voltage Rating (Typical Low ESR Electrolytic Capacitor)

The consequences of operating an electrolytic capacitor above the RMS current rating is a shortened operating life. The higher temperature speeds up the evaporation of the capacitor's electrolyte, resulting in eventual failure.

Selecting an input capacitor requires consulting the manufacturer's data sheet for maximum allowable RMS ripple current. For a maximum ambient temperature of 40°C, a general guideline would be to select a capacitor with a ripple current rating of approximately 50% of the DC load current. For ambient temperatures up to 70°C, a current rating of 75% of the DC load current would be a good choice for a conservative design. The capacitor voltage rating must be at least 1.25 times greater than the maximum input voltage, and often a much higher voltage capacitor is needed to satisfy the RMS current requirements.

A graph shown in Figure 33 shows the relationship between an electrolytic capacitor value, its voltage rating, and the RMS current it is rated for. These curves were obtained from the Nichicon "PL" series of low ESR, high reliability electrolytic capacitors designed for switching regulator applications. Other capacitor manufacturers offer similar types of capacitors, but always check the capacitor data sheet.

“Standard” electrolytic capacitors typically have much higher ESR numbers, lower RMS current ratings and typically have a shorter operating lifetime.

Because of their small size and excellent performance, surface mount solid tantalum capacitors are often used for input bypassing, but several precautions must be observed. A small percentage of solid tantalum capacitors can short if the inrush current rating is exceeded. This can happen at turn on when the input voltage is suddenly applied, and of course, higher input voltages produce higher inrush currents. Several capacitor manufacturers do a 100% surge current testing on their products to minimize this potential problem. If high turn on currents are expected, it may be necessary to limit this current by adding either some resistance or inductance before the tantalum capacitor, or select a higher voltage capacitor. As with aluminum electrolytic capacitors, the RMS ripple current rating must be sized to the load current.

OUTPUT CAPACITOR

C_{OUT} — An output capacitor is required to filter the output and provide regulator loop stability. Low impedance or low ESR Electrolytic or solid tantalum capacitors designed for switching regulator applications must be used. When selecting an output capacitor, the important capacitor parameters are; the 100 kHz Equivalent Series Resistance (ESR), the RMS ripple current rating, voltage rating, and capacitance value. For the output capacitor, the ESR value is the most important parameter.

The output capacitor requires an ESR value that has an upper and lower limit. For low output ripple voltage, a low ESR value is needed. This value is determined by the maximum allowable output ripple voltage, typically 1% to 2% of the output voltage. But if the selected capacitor's ESR is extremely low, there is a possibility of an unstable feedback loop, resulting in an oscillation at the output. Using the capacitors listed in the tables, or similar types, will provide design solutions under all conditions.

If very low output ripple voltage (less than 15 mV) is required, refer to the section on [OUTPUT VOLTAGE RIPPLE AND TRANSIENTS](#) for a post ripple filter.

An aluminum electrolytic capacitor's ESR value is related to the capacitance value and its voltage rating. In most cases, higher voltage electrolytic capacitors have lower ESR values (see [Figure 34](#)). Often, capacitors with much higher voltage ratings may be needed to provide the low ESR values required for low output ripple voltage.

The output capacitor for many different switcher designs often can be satisfied with only three or four different capacitor values and several different voltage ratings. See the quick design component selection tables in [Figure 28](#) and [Table 4](#) for typical capacitor values, voltage ratings, and manufacturers capacitor types.

Electrolytic capacitors are not recommended for temperatures below -25°C . The ESR rises dramatically at cold temperatures and typically rises 3X @ -25°C and as much as 10X at -40°C . See curve shown in [Figure 35](#).

Solid tantalum capacitors have a much better ESR spec for cold temperatures and are recommended for temperatures below -25°C .

CATCH DIODE

Buck regulators require a diode to provide a return path for the inductor current when the switch turns off. This must be a fast diode and must be located close to the LM2598 using short leads and short printed circuit traces.

Because of their very fast switching speed and low forward voltage drop, Schottky diodes provide the best performance, especially in low output voltage applications (5V and lower). Ultra-fast recovery, or High-Efficiency rectifiers are also a good choice, but some types with an abrupt turnoff characteristic may cause instability or EMI problems. Ultra-fast recovery diodes typically have reverse recovery times of 50 ns or less. Rectifiers such as the 1N5400 series are much too slow and should not be used.

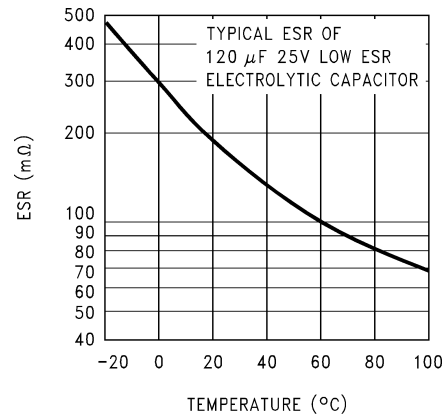

Figure 35. Capacitor ESR Change vs Temperature

INDUCTOR SELECTION

All switching regulators have two basic modes of operation; continuous and discontinuous. The difference between the two types relates to the inductor current, whether it is flowing continuously, or if it drops to zero for a period of time in the normal switching cycle. Each mode has distinctively different operating characteristics, which can affect the regulators performance and requirements. Most switcher designs will operate in the discontinuous mode when the load current is low.

The LM2598 (or any of the Simple Switcher family) can be used for both continuous or discontinuous modes of operation.

In many cases the preferred mode of operation is the continuous mode. It offers greater output power, lower peak switch, inductor and diode currents, and can have lower output ripple voltage. But it does require larger inductor values to keep the inductor current flowing continuously, especially at low output load currents and/or high input voltages.

To simplify the inductor selection process, an inductor selection guide (nomograph) was designed (see [Table 4](#) through [Figure 27](#)). This guide assumes that the regulator is operating in the continuous mode, and selects an inductor that will allow a peak-to-peak inductor ripple current to be a certain percentage of the maximum design load current. This peak-to-peak inductor ripple current percentage is not fixed, but is allowed to change as different design load currents are selected. (See [Figure 36](#).)

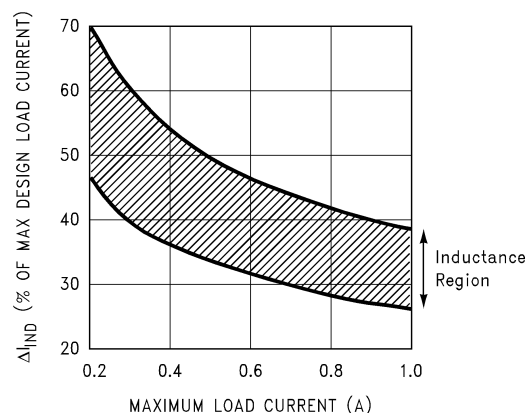

Figure 36. (ΔI_{IND}) Peak-to-Peak Inductor Ripple Current (as a Percentage of the Load Current) vs Load Current

By allowing the percentage of inductor ripple current to increase for low load currents, the inductor value and size can be kept relatively low.

When operating in the continuous mode, the inductor current waveform ranges from a triangular to a sawtooth type of waveform (depending on the input voltage), with the average value of this current waveform equal to the DC output load current.

Inductors are available in different styles such as pot core, toroid, E-core, bobbin core, etc., as well as different core materials, such as ferrites and powdered iron. The least expensive, the bobbin, rod or stick core, consists of wire wound on a ferrite bobbin. This type of construction makes for an inexpensive inductor, but since the magnetic flux is not completely contained within the core, it generates more Electro-Magnetic Interference (EMI). This magnetic flux can induce voltages into nearby printed circuit traces, thus causing problems with both the switching regulator operation and nearby sensitive circuitry, and can give incorrect scope readings because of induced voltages in the scope probe. Also see section on [OPEN CORE INDUCTORS](#).

When multiple switching regulators are located on the same PC board, open core magnetics can cause interference between two or more of the regulator circuits, especially at high currents. A torroid or E-core inductor (closed magnetic structure) should be used in these situations.

The inductors listed in the selection chart include ferrite E-core construction for Schott, ferrite bobbin core for Renco and Coilcraft, and powdered iron toroid for Pulse Engineering.

Exceeding an inductor's maximum current rating may cause the inductor to overheat because of the copper wire losses, or the core may saturate. If the inductor begins to saturate, the inductance decreases rapidly and the inductor begins to look mainly resistive (the DC resistance of the winding). This can cause the switch current to rise very rapidly and force the switch into a cycle-by-cycle current limit, thus reducing the DC output load current. This can also result in overheating of the inductor and/or the LM2598. Different inductor types have different saturation characteristics, and this should be kept in mind when selecting an inductor.

The inductor manufacturer's data sheets include current and energy limits to avoid inductor saturation.

DISCONTINUOUS MODE OPERATION

The selection guide chooses inductor values suitable for continuous mode operation, but for low current applications and/or high input voltages, a discontinuous mode design may be a better choice. It would use an inductor that would be physically smaller, and would need only one half to one third the inductance value needed for a continuous mode design. The peak switch and inductor currents will be higher in a discontinuous design, but at these low load currents (200 mA and below), the maximum switch current will still be less than the switch current limit.

Discontinuous operation can have voltage waveforms that are considerable different than a continuous design. The output pin (switch) waveform can have some damped sinusoidal ringing present. (See [Typical Performance Characteristics](#) photo titled [Figure 21](#)) This ringing is normal for discontinuous operation, and is not caused by feedback loop instabilities. In discontinuous operation, there is a period of time where neither the switch or the diode are conducting, and the inductor current has dropped to zero. During this time, a small amount of energy can circulate between the inductor and the switch/diode parasitic capacitance causing this characteristic ringing. Normally this ringing is not a problem, unless the amplitude becomes great enough to exceed the input voltage, and even then, there is very little energy present to cause damage.

Different inductor types and/or core materials produce different amounts of this characteristic ringing. Ferrite core inductors have very little core loss and therefore produce the most ringing. The higher core loss of powdered iron inductors produce less ringing. If desired, a series RC could be placed in parallel with the inductor to dampen the ringing. The computer aided design software **Switchers Made Simple** (version 4.2) will provide all component values for continuous and discontinuous modes of operation.

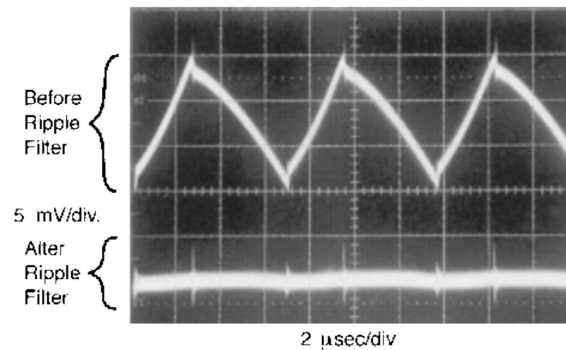

Figure 37. Post Ripple Filter Waveform

OUTPUT VOLTAGE RIPPLE AND TRANSIENTS

The output voltage of a switching power supply operating in the continuous mode will contain a sawtooth ripple voltage at the switcher frequency, and may also contain short voltage spikes at the peaks of the sawtooth waveform.

The output ripple voltage is a function of the inductor sawtooth ripple current and the ESR of the output capacitor. A typical output ripple voltage can range from approximately 0.5% to 3% of the output voltage. To obtain low ripple voltage, the ESR of the output capacitor must be low, however, caution must be exercised when using extremely low ESR capacitors because they can affect the loop stability, resulting in oscillation problems. If very low output ripple voltage is needed (less than 20 mV), a post ripple filter is recommended. (See [Figure 24](#).) The inductance required is typically between 1 μH and 5 μH , with low DC resistance, to maintain good load regulation. A low ESR output filter capacitor is also required to assure good dynamic load response and ripple reduction. The ESR of this capacitor may be as low as desired, because it is out of the regulator feedback loop. The photo shown in [Figure 37](#) shows a typical output ripple voltage, with and without a post ripple filter.

When observing output ripple with a scope, it is essential that a short, low inductance scope probe ground connection be used. Most scope probe manufacturers provide a special probe terminator which is soldered onto the regulator board, preferable at the output capacitor. This provides a very short scope ground thus eliminating the problems associated with the 3 inch ground lead normally provided with the probe, and provides a much cleaner and more accurate picture of the ripple voltage waveform.

The voltage spikes are caused by the fast switching action of the output switch, the diode, and the parasitic inductance of the output filter capacitor, and its associated wiring. To minimize these voltage spikes, the output capacitor should be designed for switching regulator applications, and the lead lengths must be kept very short. Wiring inductance, stray capacitance, as well as the scope probe used to evaluate these transients, all contribute to the amplitude of these spikes.

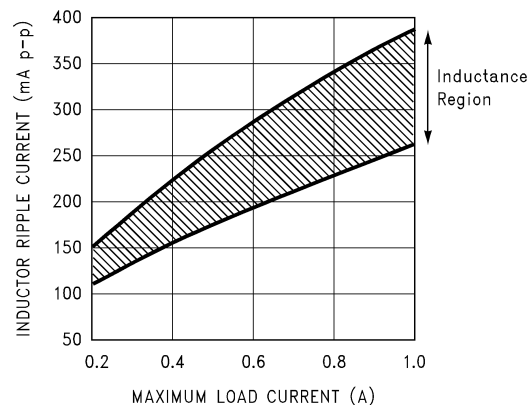

Figure 38. Peak-to-Peak Inductor Ripple Current vs Load Current

When a switching regulator is operating in the continuous mode, the inductor current waveform ranges from a triangular to a sawtooth type of waveform (depending on the input voltage). For a given input and output voltage, the peak-to-peak amplitude of this inductor current waveform remains constant. As the load current increases or decreases, the entire sawtooth current waveform also rises and falls. The average value (or the center) of this current waveform is equal to the DC load current.

If the load current drops to a low enough level, the bottom of the sawtooth current waveform will reach zero, and the switcher will smoothly change from a continuous to a discontinuous mode of operation. Most switcher designs (irregardless how large the inductor value is) will be forced to run discontinuous if the output is lightly loaded. This is a perfectly acceptable mode of operation.

In a switching regulator design, knowing the value of the peak-to-peak inductor ripple current (ΔI_{IND}) can be useful for determining a number of other circuit parameters. Parameters such as, peak inductor or peak switch current, minimum load current before the circuit becomes discontinuous, output ripple voltage and output capacitor ESR can all be calculated from the peak-to-peak ΔI_{IND} . When the inductor nomographs shown in [Figure 25](#) through [INDUCTOR VALUE SELECTION GUIDES](#) are used to select an inductor value, the peak-to-peak inductor ripple current can immediately be determined. The curve shown in [Figure 38](#) shows the range of (ΔI_{IND}) that can be expected for different load currents. The curve also shows how the peak-to-peak inductor ripple current (ΔI_{IND}) changes as you go from the lower border to the upper border (for a given load current) within an inductance region. The upper border represents a higher input voltage, while the lower border represents a lower input voltage (see [INDUCTOR SELECTION](#) Guides).

These curves are only correct for continuous mode operation, and only if the inductor selection guides are used to select the inductor value

Consider the following example:

$$V_{OUT} = 5V, \text{ maximum load current of } 800 \text{ mA}$$

$$V_{IN} = 12V, \text{ nominal, varying between } 10V \text{ and } 14V.$$

The selection guide in [Figure 26](#) shows that the vertical line for a 0.8A load current, and the horizontal line for the 12V input voltage intersect approximately midway between the upper and lower borders of the 68 μH inductance region. A 68 μH inductor will allow a peak-to-peak inductor current (ΔI_{IND}) to flow that will be a percentage of the maximum load current. Referring to [Figure 38](#), follow the 0.8A line approximately midway into the inductance region, and read the peak-to-peak inductor ripple current (ΔI_{IND}) on the left hand axis (approximately 300 mA p-p).

As the input voltage increases to 14V, it approaches the upper border of the inductance region, and the inductor ripple current increases. Referring to the curve in [Figure 38](#), it can be seen that for a load current of 0.8A, the peak-to-peak inductor ripple current (ΔI_{IND}) is 300 mA with 12V in, and can range from 340 mA at the upper border (14V in) to 225 mA at the lower border (10V in).

Once the ΔI_{IND} value is known, the following formulas can be used to calculate additional information about the switching regulator circuit.

1. Peak Inductor or peak switch current

$$= \left(I_{LOAD} + \frac{\Delta I_{IND}}{2} \right) = \left(0.8A + \frac{0.3}{2} \right) = 0.95A \quad (7)$$

2. Minimum load current before the circuit becomes discontinuous

$$= \frac{\Delta I_{IND}}{2} = \frac{0.3}{2} = 0.15A \quad (8)$$

3. Output Ripple Voltage

$$= (\Delta I_{IND}) \times (\text{ESR of } C_{OUT}) \quad (9)$$

$$= 0.3A \times 0.16\Omega = 48 \text{ mV p-p} \quad (10)$$

4. ESR of C_{OUT}

$$= \frac{\text{Output Ripple Voltage } (\Delta V_{OUT})}{\Delta I_{IND}} \quad (11)$$

$$= \frac{0.048V}{0.30A} = 0.16\Omega$$

OPEN CORE INDUCTORS

Another possible source of increased output ripple voltage or unstable operation is from an open core inductor. Ferrite bobbin or stick inductors have magnetic lines of flux flowing through the air from one end of the bobbin to the other end. These magnetic lines of flux will induce a voltage into any wire or PC board copper trace that comes within the inductor's magnetic field. The strength of the magnetic field, the orientation and location of the PC copper trace to the magnetic field, and the distance between the copper trace and the inductor, determine the amount of voltage generated in the copper trace. Another way of looking at this inductive coupling is to consider the PC board copper trace as one turn of a transformer (secondary) with the inductor winding as the primary. Many millivolts can be generated in a copper trace located near an open core inductor which can cause stability problems or high output ripple voltage problems.

If unstable operation is seen, and an open core inductor is used, it's possible that the location of the inductor with respect to other PC traces may be the problem. To determine if this is the problem, temporarily raise the inductor away from the board by several inches and then check circuit operation. If the circuit now operates correctly, then the magnetic flux from the open core inductor is causing the problem. Substituting a closed core inductor such as a toroid or E-core will correct the problem, or re-arranging the PC layout may be necessary. Magnetic flux cutting the IC device ground trace, feedback trace, or the positive or negative traces of the output capacitor should be minimized.

Sometimes, locating a trace directly beneath a bobbin inductor will provide good results, provided it is exactly in the center of the inductor (because the induced voltages cancel themselves out), but if it is off center one direction or the other, then problems could arise. If flux problems are present, even the direction of the inductor winding can make a difference in some circuits.

This discussion on open core inductors is not to frighten the user, but to alert the user on what kind of problems to watch out for when using them. Open core bobbin or "stick" inductors are an inexpensive, simple way of making a compact efficient inductor, and they are used by the millions in many different applications.

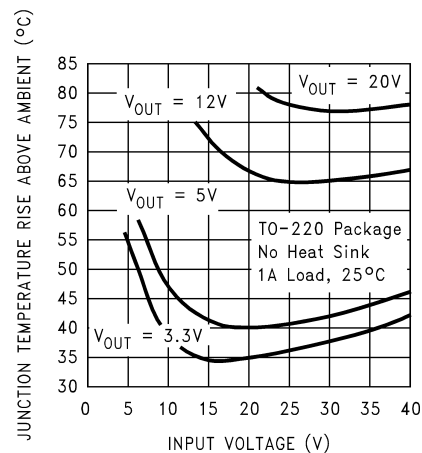

Circuit Data for Temperature Rise Curve TO-220 Package (T)

| | |
|------------|---|
| Capacitors | Through hole electrolytic |
| Inductor | Through hole, Schott, 68 μ H |
| Diode | Through hole, 3A 40V, Schottky |
| PC board | 3 square inches single sided 2 oz. copper (0.0028") |

Figure 39. Junction Temperature Rise, TO-220

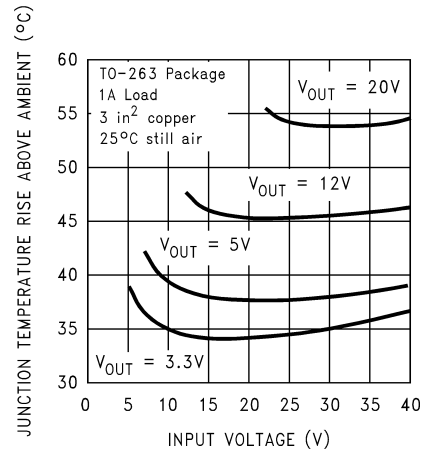

Circuit Data for Temperature Rise Curve DDPAK Package (S)

| | |
|------------|---|
| Capacitors | Surface mount tantalum, molded "D" size |
| Inductor | Surface mount, Schott, 68 µH |
| Diode | Surface mount, 3A 40V, Schottky |
| PC board | 3 square inches single sided 2 oz. copper (0.0028") |

Figure 40. Junction Temperature Rise, DDPAK

THERMAL CONSIDERATIONS

The LM2598 is available in two packages, a 7-pin TO-220 (T) and a 7-pin surface mount DDPAK (S).

The TO-220 package can be used without a heat sink for ambient temperatures up to approximately 50°C (depending on the output voltage and load current). The curves in Figure 39 show the LM2598T junction temperature rises above ambient temperature for different input and output voltages. The data for these curves was taken with the LM2598T (TO-220 package) operating as a switching regulator in an ambient temperature of 25°C (still air). These temperature rise numbers are all approximate and there are many factors that can affect these temperatures. Higher ambient temperatures require some heat sinking, either to the PC board or a small external heat sink.

The DDPAK surface mount package tab is designed to be soldered to the copper on a printed circuit board. The copper and the board are the heat sink for this package and the other heat producing components, such as the catch diode and inductor. The PC board copper area that the package is soldered to should be at least 0.4 in², and ideally should have 2 or more square inches of 2 oz. (0.0028 in) copper. Additional copper area improves the thermal characteristics, but with copper areas greater than approximately 3 in², only small improvements in heat dissipation are realized. If further thermal improvements are needed, double sided or multilayer PC-board with large copper areas are recommended.

The curves shown in Figure 40 show the LM2598S (DDPAK package) junction temperature rise above ambient temperature with a 1A load for various input and output voltages. This data was taken with the circuit operating as a buck switching regulator with all components mounted on a PC board to simulate the junction temperature under actual operating conditions. This curve can be used for a quick check for the approximate junction temperature for various conditions, but be aware that there are many factors that can affect the junction temperature.

For the best thermal performance, wide copper traces and generous amounts of printed circuit board copper should be used in the board layout. (One exception to this is the output (switch) pin, which should not have large areas of copper.) Large areas of copper provide the best transfer of heat (lower thermal resistance) to the surrounding air, and moving air lowers the thermal resistance even further.

Package thermal resistance and junction temperature rise numbers are all approximate, and there are many factors that will affect these numbers. Some of these factors include board size, shape, thickness, position, location, and even board temperature. Other factors are, trace width, total printed circuit copper area, copper thickness, single- or double-sided, multilayer board and the amount of solder on the board. The effectiveness of the PC board to dissipate heat also depends on the size, quantity and spacing of other components on the board, as well as whether the surrounding air is still or moving. Furthermore, some of these components such as the catch diode will add heat to the PC board and the heat can vary as the input voltage changes. For the inductor, depending on the physical size, type of core material and the DC resistance, it could either act as a heat sink taking heat away from the board, or it could add heat to the board.

SHUTDOWN /SOFT-START

The circuit shown in [Figure 43](#) is a standard buck regulator with 24V in, 12V out, 280 mA load, and using a 0.068 μF Soft-start capacitor. The photo in [Figure 41](#) and [Figure 42](#) show the effects of Soft-start on the output voltage, the input current, with, and without a Soft-start capacitor. [Figure 41](#) also shows the error flag output going high when the output voltage reaches 95% of the nominal output voltage. The reduced input current required at startup is very evident when comparing the two photos. The Soft-start feature reduces the startup current from 1A down to 240 mA, and delays and slows down the output voltage rise time.

This reduction in start up current is useful in situations where the input power source is limited in the amount of current it can deliver. In some applications Soft-start can be used to replace undervoltage lockout or delayed startup functions.

If a very slow output voltage ramp is desired, the Soft-start capacitor can be made much larger. Many seconds or even minutes are possible.

If only the shutdown feature is needed, the Soft-start capacitor can be eliminated.

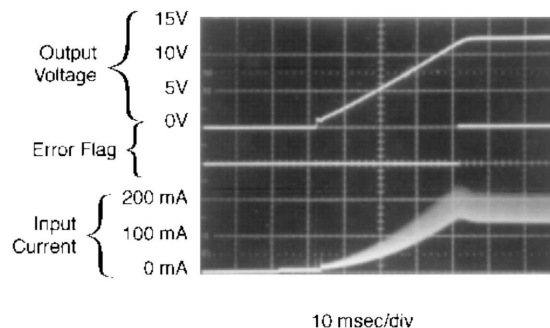

Figure 41. Output Voltage, Input Current, Error Flag Signal, at Start-Up, WITH Soft-start

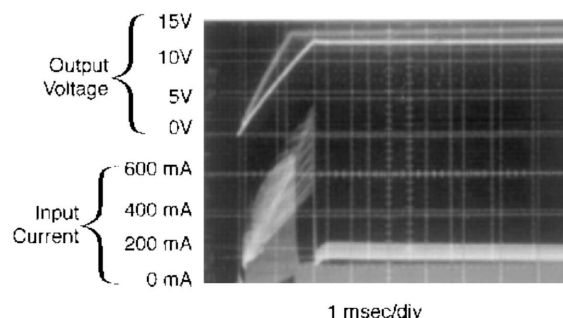

Figure 42. Output Voltage, Input Current, at Start-Up, WITHOUT Soft-start

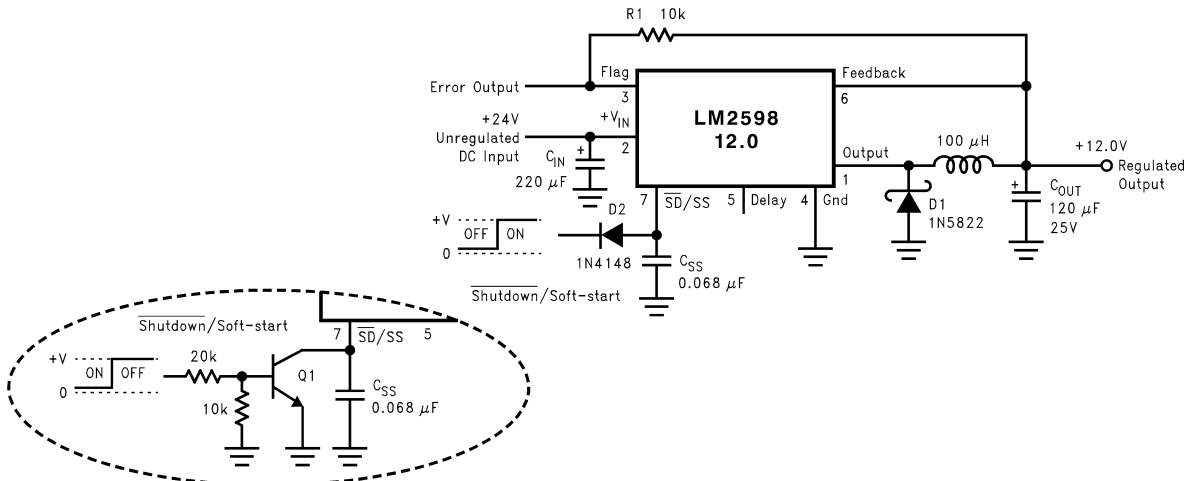

Figure 43. Typical Circuit Using Shutdown /Soft-start and Error Flag Features

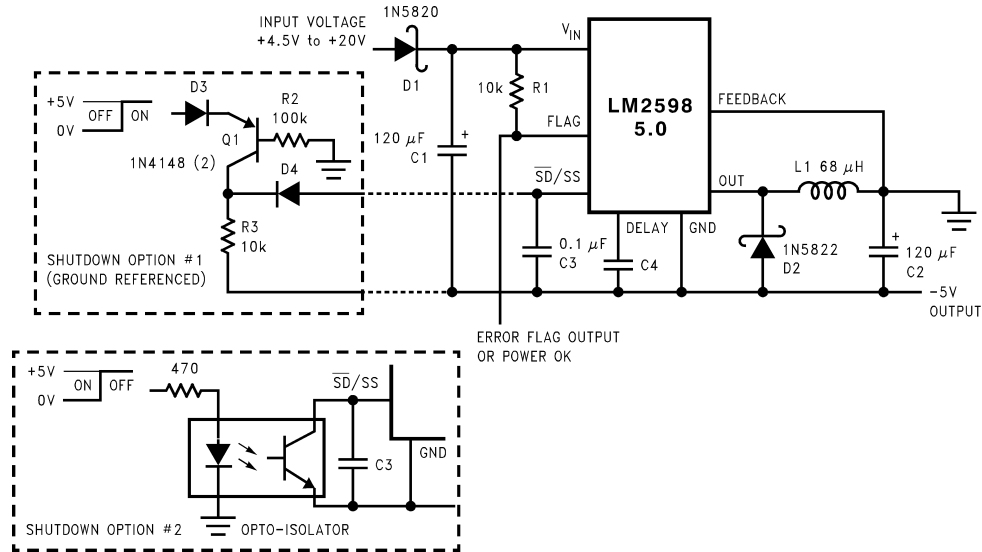

Figure 44. Inverting -5V Regulator With Shutdown and Soft-start

INVERTING REGULATOR

The circuit in [Figure 44](#) converts a positive input voltage to a negative output voltage with a common ground. The circuit operates by bootstrapping the regulator's ground pin to the negative output voltage, then grounding the feedback pin, the regulator senses the inverted output voltage and regulates it.

This example uses the LM2598-5 to generate a -5V output, but other output voltages are possible by selecting other output voltage versions, including the adjustable version. Since this regulator topology can produce an output voltage that is either greater than or less than the input voltage, the maximum output current greatly depends on both the input and output voltage. The curve shown in [Figure 45](#) provides a guide as to the amount of output load current possible for the different input and output voltage conditions.

The maximum voltage appearing across the regulator is the absolute sum of the input and output voltage, and this must be limited to a maximum of 40V. In this example, when converting +20V to -5V, the regulator would see 25V between the input pin and ground pin. The LM2598 has a maximum input voltage rating of 40V.

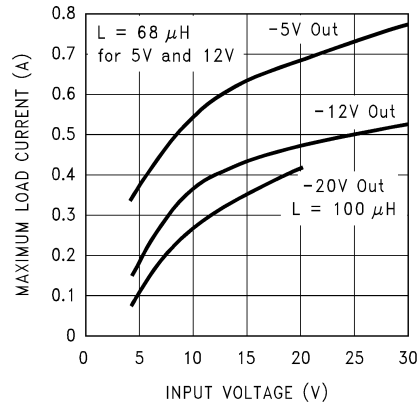

Figure 45. Maximum Load Current for Inverting Regulator Circuit

An additional diode is required in this regulator configuration. Diode D1 is used to isolate input voltage ripple or noise from coupling through the C_{IN} capacitor to the output, under light or no load conditions. Also, this diode isolation changes the topology to closely resemble a buck configuration thus providing good closed loop stability. A Schottky diode is recommended for low input voltages, (because of its lower voltage drop) but for higher input voltages, a 1N5400 diode could be used.

Because of differences in the operation of the inverting regulator, the standard design procedure is not used to select the inductor value. In the majority of designs, a 68 μH , 1.5 Amp inductor is the best choice. Capacitor selection can also be narrowed down to just a few values. Using the values shown in Figure 44 will provide good results in the majority of inverting designs.

This type of inverting regulator can require relatively large amounts of input current when starting up, even with light loads. Input currents as high as the LM2598 current limit (approximately 1.5A) are needed for 2 ms or more, until the output reaches its nominal output voltage. The actual time depends on the output voltage and the size of the output capacitor. Input power sources that are current limited or sources that can not deliver these currents without getting loaded down, may not work correctly. Because of the relatively high startup currents required by the inverting topology, the Soft-start feature shown in Figure 44 is recommended.

Also shown in Figure 44 are several shutdown methods for the inverting configuration. With the inverting configuration, some level shifting is required, because the ground pin of the regulator is no longer at ground, but is now at the negative output voltage. The shutdown methods shown accept ground referenced shutdown signals.

UNDERVOLTAGE LOCKOUT

Some applications require the regulator to remain off until the input voltage reaches a predetermined voltage. Figure 46 contains a undervoltage lockout circuit for a buck configuration, while Figure 47 and Figure 48 are for the inverting types (only the circuitry pertaining to the undervoltage lockout is shown). Figure 46 uses a zener diode to establish the threshold voltage when the switcher begins operating. When the input voltage is less than the zener voltage, resistors R1 and R2 hold the Shutdown /Soft-start pin low, keeping the regulator in the shutdown mode. As the input voltage exceeds the zener voltage, the zener conducts, pulling the Shutdown /Soft-start pin high, allowing the regulator to begin switching. The threshold voltage for the undervoltage lockout feature is approximately 1.5V greater than the zener voltage.

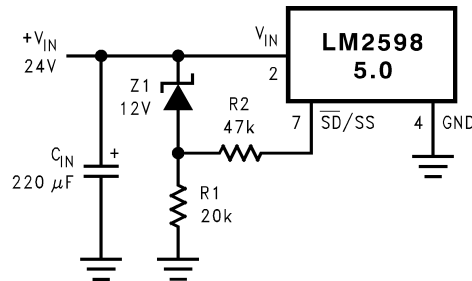

Figure 46. Undervoltage Lockout for a Buck Regulator

Figure 47 and Figure 48 apply the same feature to an inverting circuit. Figure 47 features a constant threshold voltage for turn on and turn off (zener voltage plus approximately one volt). Since the \overline{SD}/SS pin has an internal 7V zener clamp, R2 is needed to limit the current into this pin to approximately 1 mA when Q1 is on. If hysteresis is needed, the circuit in Figure 48 has a turn ON voltage which is different than the turn OFF voltage. The amount of hysteresis is approximately equal to the value of the output voltage.

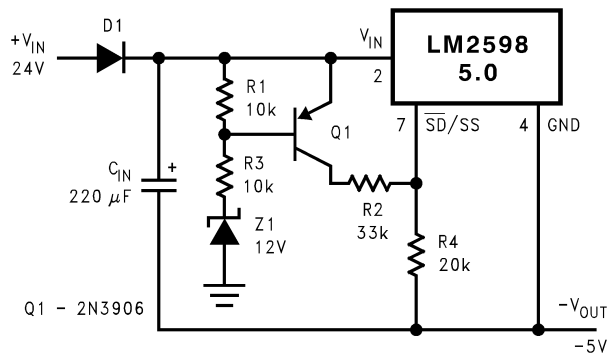

Figure 47. Undervoltage Lockout Without Hysteresis for an Inverting Regulator

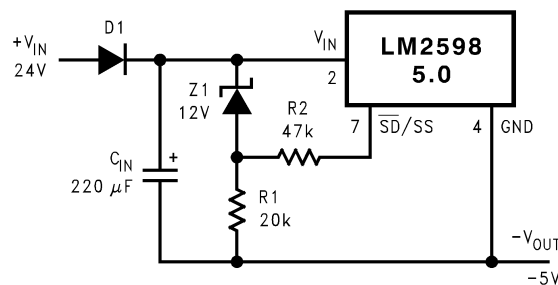

Figure 48. Undervoltage Lockout With Hysteresis for an Inverting Regulator

NEGATIVE VOLTAGE CHARGE PUMP

Occasionally a low current negative voltage is needed for biasing parts of a circuit. A simple method of generating a negative voltage using a charge pump technique and the switching waveform present at the OUT pin, is shown in Figure 49. This unregulated negative voltage is approximately equal to the positive input voltage (minus a few volts), and can supply up to a 200 mA of output current. There is a requirement however, that there be a minimum load of several hundred mA on the regulated positive output for the charge pump to work correctly. Also, resistor R1 is required to limit the charging current of C1 to some value less than the LM2598 current limit (typically 1.5A).

This method of generating a negative output voltage without an additional inductor can be used with other members of the Simple Switcher Family, using either the buck or boost topology.

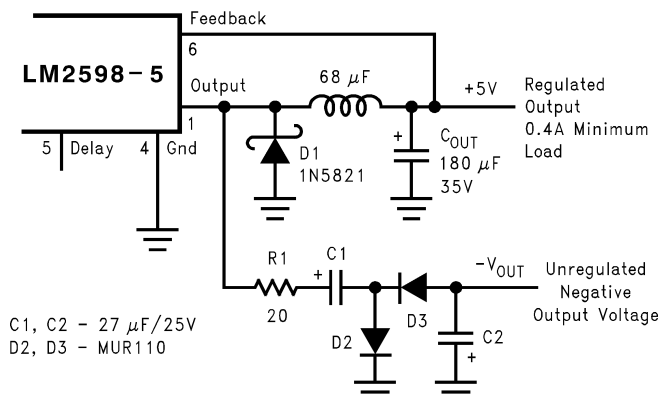
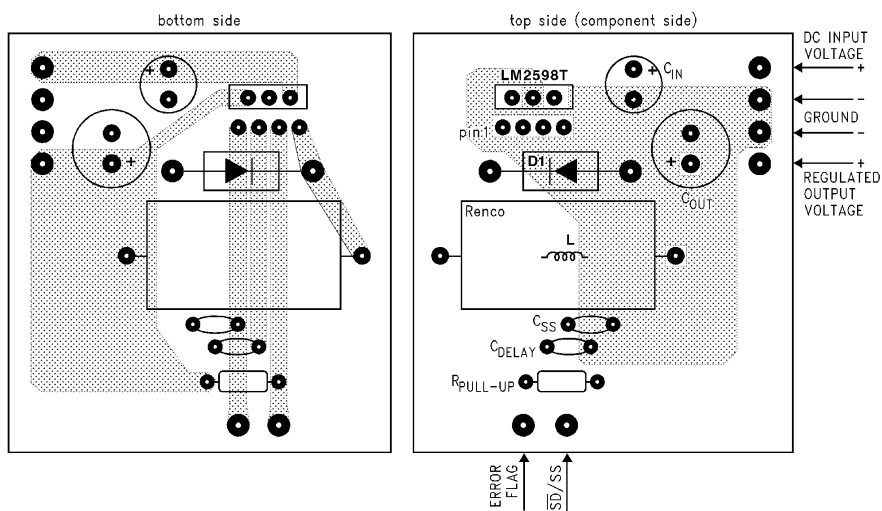

Figure 49. Charge Pump for Generating a Low Current, Negative Output Voltage

TYPICAL THROUGH HOLE PC BOARD LAYOUT, FIXED OUTPUT (1X SIZE), DOUBLE SIDED, THROUGH HOLE PLATED



C_{IN}—150 μF/50V Aluminum Electrolytic, Panasonic “HFQ series”

R_{PULL-UP}—10 kΩ

C_{OUT}—120 μF/25V Aluminum Electrolytic, Panasonic “HFQ series”

C_{DELAY}—0.1 μF

D1—3A, 40V Schottky Rectifier, 1N5822

C_{SD/SS}—0.1 μF

L1—68 μH, L30, Renco, Through hole

Figure 50. Fixed Output PC Board Layout

TYPICAL THROUGH HOLE PC BOARD LAYOUT, ADJUSTABLE OUTPUT (1X SIZE), DOUBLE SIDED, THROUGH HOLE PLATED

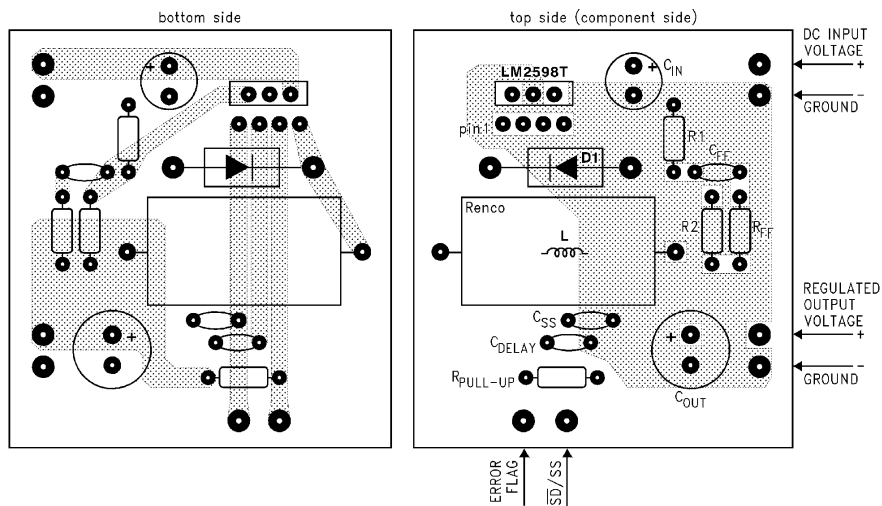

C_{IN} —150 μ F/50V, Aluminum Electrolytic, Panasonic “HFQ series”

C_{OUT} —120 μ F/25V Aluminum Electrolytic, Panasonic “HFQ series”

D1—3A, 40V Schottky Rectifier, 1N5822

L1—68 μ H, L30, Renco, Through hole

R1—1 k Ω , 1%

R2—Use formula in Design Procedure

C_{FF} —See Figure 25.

R_{FF} —See Application Information Section (C_{FF} Section)

$R_{PULL-UP}$ —10 k Ω

C_{DELAY} —0.1 μ F

$C_{SD/SS}$ —0.1 μ F

Figure 51. Adjustable Output PC Board Layout

REVISION HISTORY

| Changes from Revision B (April 2013) to Revision C | Page |
|--|--------------------|
| • Changed layout of National Data Sheet to TI format | 37 |

PACKAGING INFORMATION

| Orderable Device | Status (1) | Package Type | Package Drawing | Pins | Package Qty | Eco Plan (2) | Lead/Ball Finish | MSL Peak Temp (3) | Op Temp (°C) | Device Marking (4/5) | Samples |
|-------------------|---------------|------------------|-----------------|------|-------------|--------------------------|------------------|----------------------|--------------|-------------------------|-------------------------|
| LM2598S-12 | ACTIVE | DDPAK/ TO-263 | KTW | 7 | | TBD | Call TI | Call TI | -40 to 125 | LM2598S -12 P+ | Samples |
| LM2598S-12/NOPB | ACTIVE | DDPAK/ TO-263 | KTW | 7 | 45 | Pb-Free (RoHS Exempt) | CU SN | Level-3-245C-168 HR | -40 to 125 | LM2598S -12 P+ | Samples |
| LM2598S-3.3 | ACTIVE | DDPAK/ TO-263 | KTW | 7 | | TBD | Call TI | Call TI | -40 to 125 | LM2598S -3.3 P+ | Samples |
| LM2598S-3.3/NOPB | ACTIVE | DDPAK/ TO-263 | KTW | 7 | 45 | Pb-Free (RoHS Exempt) | CU SN | Level-3-245C-168 HR | -40 to 125 | LM2598S -3.3 P+ | Samples |
| LM2598S-5.0 | ACTIVE | DDPAK/ TO-263 | KTW | 7 | 45 | TBD | Call TI | Call TI | -40 to 125 | LM2598S -5.0 P+ | Samples |
| LM2598S-5.0/NOPB | ACTIVE | DDPAK/ TO-263 | KTW | 7 | 45 | Pb-Free (RoHS Exempt) | CU SN | Level-3-245C-168 HR | -40 to 125 | LM2598S -5.0 P+ | Samples |
| LM2598S-ADJ | ACTIVE | DDPAK/ TO-263 | KTW | 7 | | TBD | Call TI | Call TI | -40 to 125 | LM2598S -ADJ P+ | Samples |
| LM2598S-ADJ/NOPB | ACTIVE | DDPAK/ TO-263 | KTW | 7 | 45 | Pb-Free (RoHS Exempt) | CU SN | Level-3-245C-168 HR | -40 to 125 | LM2598S -ADJ P+ | Samples |
| LM2598SX-12 | ACTIVE | DDPAK/ TO-263 | KTW | 7 | 500 | TBD | Call TI | Call TI | -40 to 125 | LM2598S -12 P+ | Samples |
| LM2598SX-12/NOPB | ACTIVE | DDPAK/ TO-263 | KTW | 7 | 500 | Pb-Free (RoHS Exempt) | CU SN | Level-3-245C-168 HR | -40 to 125 | LM2598S -12 P+ | Samples |
| LM2598SX-3.3 | ACTIVE | DDPAK/ TO-263 | KTW | 7 | | TBD | Call TI | Call TI | -40 to 125 | LM2598S -3.3 P+ | Samples |
| LM2598SX-3.3/NOPB | ACTIVE | DDPAK/ TO-263 | KTW | 7 | 500 | Pb-Free (RoHS Exempt) | CU SN | Level-3-245C-168 HR | -40 to 125 | LM2598S -3.3 P+ | Samples |
| LM2598SX-5.0 | ACTIVE | DDPAK/ TO-263 | KTW | 7 | 500 | TBD | Call TI | Call TI | -40 to 125 | LM2598S -5.0 P+ | Samples |
| LM2598SX-5.0/NOPB | ACTIVE | DDPAK/ TO-263 | KTW | 7 | 500 | Pb-Free (RoHS Exempt) | CU SN | Level-3-245C-168 HR | -40 to 125 | LM2598S -5.0 P+ | Samples |
| LM2598SX-ADJ | ACTIVE | DDPAK/ TO-263 | KTW | 7 | | TBD | Call TI | Call TI | -40 to 125 | LM2598S -ADJ P+ | Samples |
| LM2598SX-ADJ/NOPB | ACTIVE | DDPAK/ TO-263 | KTW | 7 | 500 | Pb-Free (RoHS Exempt) | CU SN | Level-3-245C-168 HR | -40 to 125 | LM2598S -ADJ P+ | Samples |
| LM2598T-12 | ACTIVE | TO-220 | NDZ | 7 | | TBD | Call TI | Call TI | -40 to 125 | LM2598T -12 P+ | Samples |

| Orderable Device | Status (1) | Package Type | Package Drawing | Pins | Package Qty | Eco Plan (2) | Lead/Ball Finish | MSL Peak Temp (3) | Op Temp (°C) | Device Marking (4/5) | Samples |
|------------------|---------------|--------------|-----------------|------|-------------|-------------------------|------------------|----------------------|--------------|-------------------------|-------------------------|
| LM2598T-12/NOPB | ACTIVE | TO-220 | NDZ | 7 | 45 | Green (RoHS & no Sb/Br) | CU SN | Level-1-NA-UNLIM | -40 to 125 | LM2598T -12 P+ | Samples |
| LM2598T-3.3 | ACTIVE | TO-220 | NDZ | 7 | | TBD | Call TI | Call TI | -40 to 125 | LM2598T -3.3 P+ | Samples |
| LM2598T-3.3/NOPB | ACTIVE | TO-220 | NDZ | 7 | 45 | Green (RoHS & no Sb/Br) | CU SN | Level-1-NA-UNLIM | -40 to 125 | LM2598T -3.3 P+ | Samples |
| LM2598T-5.0 | ACTIVE | TO-220 | NDZ | 7 | | TBD | Call TI | Call TI | -40 to 125 | LM2598T -5.0 P+ | Samples |
| LM2598T-5.0/NOPB | ACTIVE | TO-220 | NDZ | 7 | 45 | Green (RoHS & no Sb/Br) | CU SN | Level-1-NA-UNLIM | -40 to 125 | LM2598T -5.0 P+ | Samples |
| LM2598T-ADJ | ACTIVE | TO-220 | NDZ | 7 | | TBD | Call TI | Call TI | -40 to 125 | LM2598T -ADJ P+ | Samples |
| LM2598T-ADJ/NOPB | ACTIVE | TO-220 | NDZ | 7 | 45 | Green (RoHS & no Sb/Br) | CU SN | Level-1-NA-UNLIM | -40 to 125 | LM2598T -ADJ P+ | Samples |

(1) The marketing status values are defined as follows:

ACTIVE: Product device recommended for new designs.

LIFEBUY: TI has announced that the device will be discontinued, and a lifetime-buy period is in effect.

NRND: Not recommended for new designs. Device is in production to support existing customers, but TI does not recommend using this part in a new design.

PREVIEW: Device has been announced but is not in production. Samples may or may not be available.

OBSELETE: TI has discontinued the production of the device.

(2) Eco Plan - The planned eco-friendly classification: Pb-Free (RoHS), Pb-Free (RoHS Exempt), or Green (RoHS & no Sb/Br) - please check <http://www.ti.com/productcontent> for the latest availability information and additional product content details.

TBD: The Pb-Free/Green conversion plan has not been defined.

Pb-Free (RoHS): TI's terms "Lead-Free" or "Pb-Free" mean semiconductor products that are compatible with the current RoHS requirements for all 6 substances, including the requirement that lead not exceed 0.1% by weight in homogeneous materials. Where designed to be soldered at high temperatures, TI Pb-Free products are suitable for use in specified lead-free processes.

Pb-Free (RoHS Exempt): This component has a RoHS exemption for either 1) lead-based flip-chip solder bumps used between the die and package, or 2) lead-based die adhesive used between the die and leadframe. The component is otherwise considered Pb-Free (RoHS compatible) as defined above.

Green (RoHS & no Sb/Br): TI defines "Green" to mean Pb-Free (RoHS compatible), and free of Bromine (Br) and Antimony (Sb) based flame retardants (Br or Sb do not exceed 0.1% by weight in homogeneous material)

(3) MSL, Peak Temp. -- The Moisture Sensitivity Level rating according to the JEDEC industry standard classifications, and peak solder temperature.

(4) There may be additional marking, which relates to the logo, the lot trace code information, or the environmental category on the device.

(5) Multiple Device Markings will be inside parentheses. Only one Device Marking contained in parentheses and separated by a "-" will appear on a device. If a line is indented then it is a continuation of the previous line and the two combined represent the entire Device Marking for that device.

Important Information and Disclaimer: The information provided on this page represents TI's knowledge and belief as of the date that it is provided. TI bases its knowledge and belief on information provided by third parties, and makes no representation or warranty as to the accuracy of such information. Efforts are underway to better integrate information from third parties. TI has taken and continues to take reasonable steps to provide representative and accurate information but may not have conducted destructive testing or chemical analysis on incoming materials and chemicals. TI and TI suppliers consider certain information to be proprietary, and thus CAS numbers and other limited information may not be available for release.

In no event shall TI's liability arising out of such information exceed the total purchase price of the TI part(s) at issue in this document sold by TI to Customer on an annual basis.

TAPE AND REEL INFORMATION

QUADRANT ASSIGNMENTS FOR PIN 1 ORIENTATION IN TAPE

*All dimensions are nominal

| Device | Package Type | Package Drawing | Pins | SPQ | Reel Diameter (mm) | Reel Width W1 (mm) | A0 (mm) | B0 (mm) | K0 (mm) | P1 (mm) | W (mm) | Pin1 Quadrant |
|-------------------|------------------|-----------------|------|-----|--------------------|--------------------|---------|---------|---------|---------|--------|---------------|
| LM2598SX-12 | DDPAK/ TO-263 | KTW | 7 | 500 | 330.0 | 24.4 | 10.75 | 14.85 | 5.0 | 16.0 | 24.0 | Q2 |
| LM2598SX-12/NOPB | DDPAK/ TO-263 | KTW | 7 | 500 | 330.0 | 24.4 | 10.75 | 14.85 | 5.0 | 16.0 | 24.0 | Q2 |
| LM2598SX-3.3/NOPB | DDPAK/ TO-263 | KTW | 7 | 500 | 330.0 | 24.4 | 10.75 | 14.85 | 5.0 | 16.0 | 24.0 | Q2 |
| LM2598SX-5.0 | DDPAK/ TO-263 | KTW | 7 | 500 | 330.0 | 24.4 | 10.75 | 14.85 | 5.0 | 16.0 | 24.0 | Q2 |
| LM2598SX-5.0/NOPB | DDPAK/ TO-263 | KTW | 7 | 500 | 330.0 | 24.4 | 10.75 | 14.85 | 5.0 | 16.0 | 24.0 | Q2 |
| LM2598SX-ADJ/NOPB | DDPAK/ TO-263 | KTW | 7 | 500 | 330.0 | 24.4 | 10.75 | 14.85 | 5.0 | 16.0 | 24.0 | Q2 |

TAPE AND REEL BOX DIMENSIONS

*All dimensions are nominal

| Device | Package Type | Package Drawing | Pins | SPQ | Length (mm) | Width (mm) | Height (mm) |
|-------------------|--------------|-----------------|------|-----|-------------|------------|-------------|
| LM2598SX-12 | DDPAK/TO-263 | KTW | 7 | 500 | 367.0 | 367.0 | 45.0 |
| LM2598SX-12/NOPB | DDPAK/TO-263 | KTW | 7 | 500 | 367.0 | 367.0 | 45.0 |
| LM2598SX-3.3/NOPB | DDPAK/TO-263 | KTW | 7 | 500 | 367.0 | 367.0 | 45.0 |
| LM2598SX-5.0 | DDPAK/TO-263 | KTW | 7 | 500 | 367.0 | 367.0 | 45.0 |
| LM2598SX-5.0/NOPB | DDPAK/TO-263 | KTW | 7 | 500 | 367.0 | 367.0 | 45.0 |
| LM2598SX-ADJ/NOPB | DDPAK/TO-263 | KTW | 7 | 500 | 367.0 | 367.0 | 45.0 |

KTW0007B

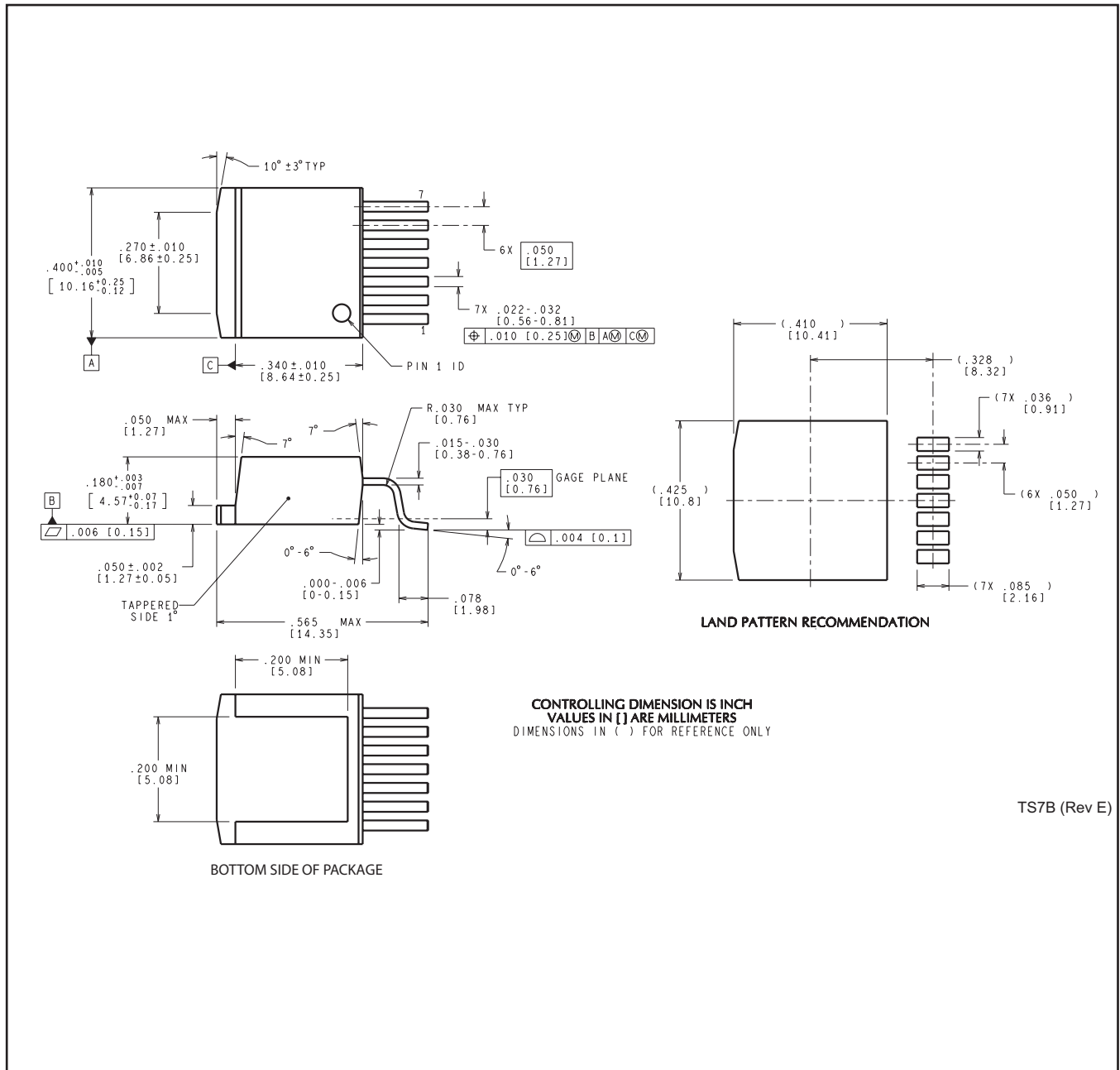

TS7B (Rev E)

IMPORTANT NOTICE

Texas Instruments Incorporated and its subsidiaries (TI) reserve the right to make corrections, enhancements, improvements and other changes to its semiconductor products and services per JESD46, latest issue, and to discontinue any product or service per JESD48, latest issue. Buyers should obtain the latest relevant information before placing orders and should verify that such information is current and complete. All semiconductor products (also referred to herein as "components") are sold subject to TI's terms and conditions of sale supplied at the time of order acknowledgment.

TI warrants performance of its components to the specifications applicable at the time of sale, in accordance with the warranty in TI's terms and conditions of sale of semiconductor products. Testing and other quality control techniques are used to the extent TI deems necessary to support this warranty. Except where mandated by applicable law, testing of all parameters of each component is not necessarily performed.

TI assumes no liability for applications assistance or the design of Buyers' products. Buyers are responsible for their products and applications using TI components. To minimize the risks associated with Buyers' products and applications, Buyers should provide adequate design and operating safeguards.

TI does not warrant or represent that any license, either express or implied, is granted under any patent right, copyright, mask work right, or other intellectual property right relating to any combination, machine, or process in which TI components or services are used. Information published by TI regarding third-party products or services does not constitute a license to use such products or services or a warranty or endorsement thereof. Use of such information may require a license from a third party under the patents or other intellectual property of the third party, or a license from TI under the patents or other intellectual property of TI.

Reproduction of significant portions of TI information in TI data books or data sheets is permissible only if reproduction is without alteration and is accompanied by all associated warranties, conditions, limitations, and notices. TI is not responsible or liable for such altered documentation. Information of third parties may be subject to additional restrictions.

Resale of TI components or services with statements different from or beyond the parameters stated by TI for that component or service voids all express and any implied warranties for the associated TI component or service and is an unfair and deceptive business practice. TI is not responsible or liable for any such statements.

Buyer acknowledges and agrees that it is solely responsible for compliance with all legal, regulatory and safety-related requirements concerning its products, and any use of TI components in its applications, notwithstanding any applications-related information or support that may be provided by TI. Buyer represents and agrees that it has all the necessary expertise to create and implement safeguards which anticipate dangerous consequences of failures, monitor failures and their consequences, lessen the likelihood of failures that might cause harm and take appropriate remedial actions. Buyer will fully indemnify TI and its representatives against any damages arising out of the use of any TI components in safety-critical applications.

In some cases, TI components may be promoted specifically to facilitate safety-related applications. With such components, TI's goal is to help enable customers to design and create their own end-product solutions that meet applicable functional safety standards and requirements. Nonetheless, such components are subject to these terms.

No TI components are authorized for use in FDA Class III (or similar life-critical medical equipment) unless authorized officers of the parties have executed a special agreement specifically governing such use.

Only those TI components which TI has specifically designated as military grade or "enhanced plastic" are designed and intended for use in military/aerospace applications or environments. Buyer acknowledges and agrees that any military or aerospace use of TI components which have **not** been so designated is solely at the Buyer's risk, and that Buyer is solely responsible for compliance with all legal and regulatory requirements in connection with such use.

TI has specifically designated certain components as meeting ISO/TS16949 requirements, mainly for automotive use. In any case of use of non-designated products, TI will not be responsible for any failure to meet ISO/TS16949.

Products

| | |
|------------------------------|--|
| Audio | www.ti.com/audio |
| Amplifiers | amplifier.ti.com |
| Data Converters | dataconverter.ti.com |
| DLP® Products | www.dlp.com |
| DSP | dsp.ti.com |
| Clocks and Timers | www.ti.com/clocks |
| Interface | interface.ti.com |
| Logic | logic.ti.com |
| Power Mgmt | power.ti.com |
| Microcontrollers | microcontroller.ti.com |
| RFID | www.ti-rfid.com |
| OMAP Applications Processors | www.ti.com/omap |
| Wireless Connectivity | www.ti.com/wirelessconnectivity |

Applications

| | |
|-------------------------------|--|
| Automotive and Transportation | www.ti.com/automotive |
| Communications and Telecom | www.ti.com/communications |
| Computers and Peripherals | www.ti.com/computers |
| Consumer Electronics | www.ti.com/consumer-apps |
| Energy and Lighting | www.ti.com/energy |
| Industrial | www.ti.com/industrial |
| Medical | www.ti.com/medical |
| Security | www.ti.com/security |
| Space, Avionics and Defense | www.ti.com/space-avionics-defense |
| Video and Imaging | www.ti.com/video |

TI E2E Community

e2e.ti.com